

Revision: Engines with pressure oil chain tensioner added.

Models 200 D/8, 220 D/8, 200/8, 220/8

General Instructions

Instead of using a tension sprocket, the drive chain of the above engine models is tightened by a tensioning rail (3) which is so arranged that the chain slides over it. Removal and installation of the tensioning rail is effected with cylinder head assembled (Figs. 05-1/1 to 4).

Caution: Do not crank the engine by the camshaft sprocket hexagon bolt - resulting overload might otherwise bend tensioning rail out of shape.

1st Version

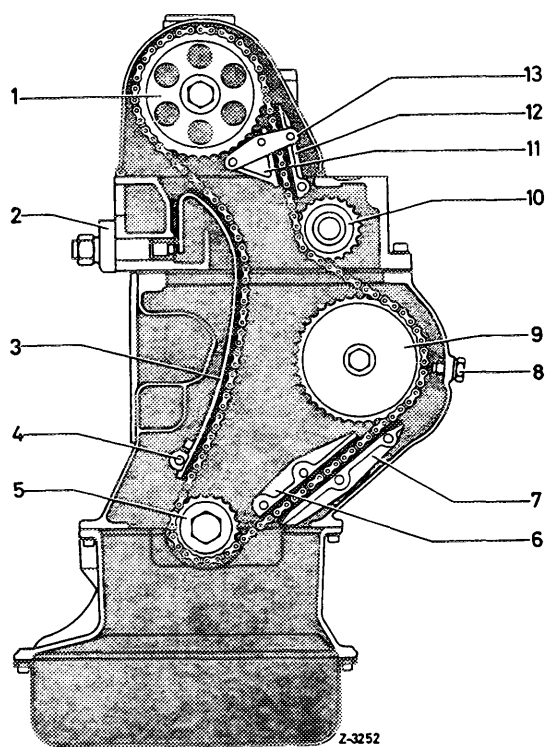

Fig. 05-1/1

Chain drive Models 200 D/8 and 220 D/8

- | | |
|--|--|
| 1 Camshaft sprocket | 10 Reversing sprocket |
| 2 Chain tightener | 11 Chain guide, inside |
| 3 Tensioning rail | 12 Chain guide, outside |
| 4 Bearing bolt | 13 Support bracket for chain guide, inside |
| 5 Crankshaft sprocket | |
| 6 Chain guide, inside | |
| 7 Chain guide, outside | |
| 8 Locking screw | |
| 9 Intermediate gear (drive gear for injection pump and oil pump) | |

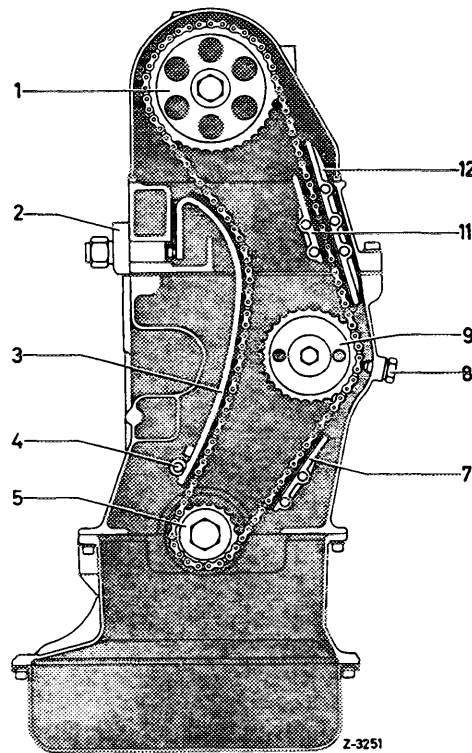

Fig. 05-1/2

Chain drive Models 200/8 and 220/8

- | | |
|--|-------------------------|
| 1 Camshaft sprocket | 11 Chain guide, inside |
| 2 Chain tightener | 12 Chain guide, outside |
| 3 Tensioning rail | |
| 4 Bearing bolt | |
| 5 Crankshaft sprocket | |
| 7 Chain guide | |
| 8 Locking screw | |
| 9 Intermediate gear driving oil pump and distributor | |

2nd Version without oil weir for chain tensioner (pressure oil chain tensioner) and without locking wire for tensioning rail mountings.

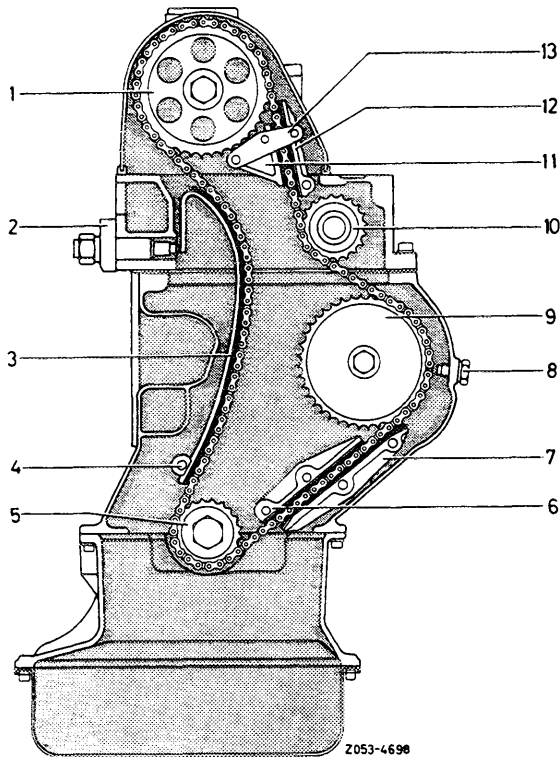

Fig. 05-1/3

Chain Drive Models 200 D/8 and 220 D/8

- | | |
|-----------------------|--|
| 1 Camshaft gear | 8 Locking screw |
| 2 Chain tensioner | 9 Intermediate gear (drive for injection timer, injection pump and oil pump) |
| 3 Tensioning rail | 10 Reversing sprocket |
| 4 Bearing bolt | 11 Chain guide inside |
| 5 Crankshaft sprocket | 12 Chain guide outside |
| 6 Chain guide inside | 13 Bracket for chain guide inside |
| 7 Chain guide outside | |

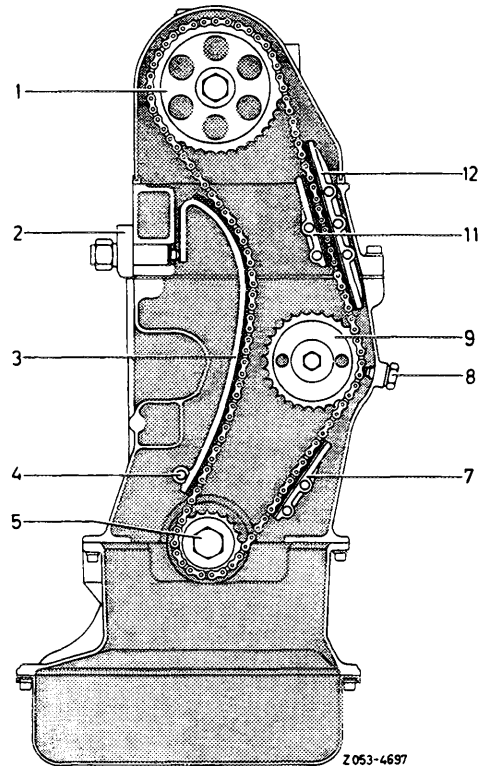

Fig. 05-1/4

Chain Drive Models 200/8 and 220/8

- | | |
|-----------------------|---|
| 1 Camshaft gear | 9 Intermediate gear (drive for oil pump and ignition distributor) |
| 2 Chain tensioner | |
| 3 Tensioning rail | |
| 4 Bearing bolt | |
| 5 Crankshaft sprocket | 11 Chain guide inside |
| 7 Chain guide | 12 Chain guide outside |
| 8 Locking screw | |

Removal

- 1 Remove radiator with shell and fan blade.
- 2 Turn crankshaft at hex bolt for attaching balancing disc in direction of rotation of engine until recess on balancing disc faces bearing bolt (Fig. 05-1/7). Use socket wrench insert Part No. 001 589 65 09 00 (Fig. 05-1/5).
- 3 Remove cylinder head cover.
- 4 Remove thermostat housing
- 5 Remove chain tensioner (2) (Figs. 05-1/1 to 4)

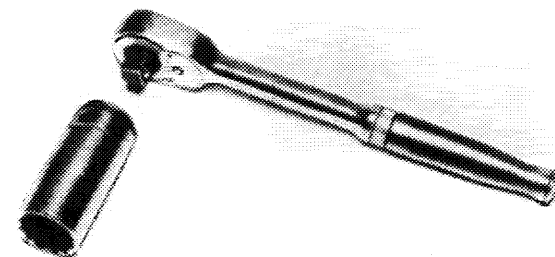

Fig. 05-1/5

R 100/6496

6 Attach installation device Part No. 115 589 14 61 00 to tensioning rail (Fig. 05-1/6).

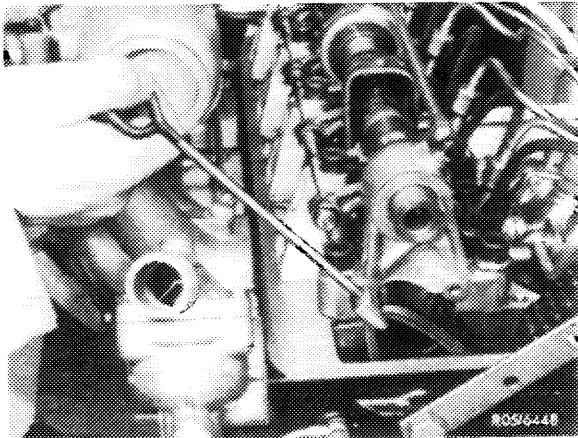

Fig. 05-1/6

7 Pull out tensioning rail bearing bolt. Two pullers are available for this purpose:

a) With puller Part No. 115 589 07 33 00, only the bearing bolt of the 1st version with wire lock on tensioning rail can be pulled out (Fig. 05-1/7).

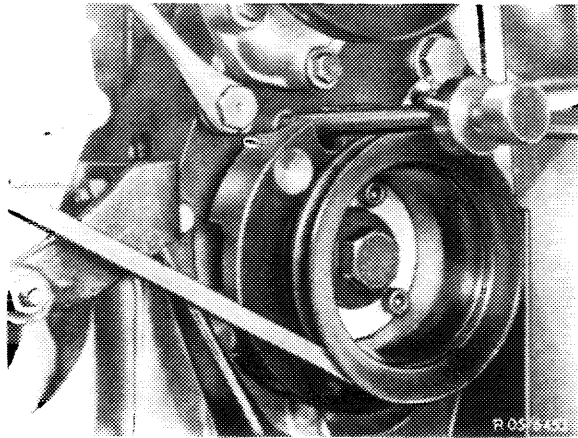

Fig. 05-1/7

b) Knock out bearing bolt of 2nd version, without wire lock on tensioning rail (Fig. 05-1/8) by means of impact puller basic tool 116 589 20 33 00 and threaded bolt M 6, 116 589 02 34 00 or M 8, 116 589 03 34 00 (Fig. 05-1/9).

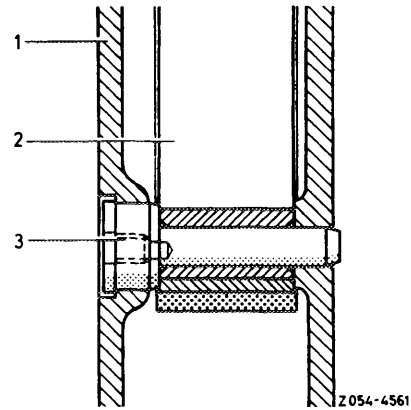

Fig. 05-1/8

1 Cylinder crankcase 3 Bearing bolt
2 Tensioning rail

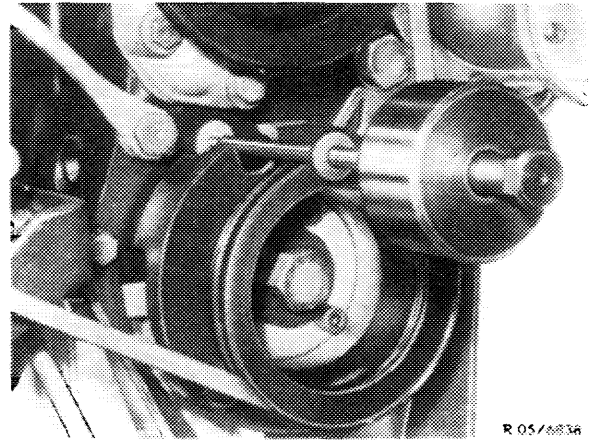

Fig. 05-1/9

This impact puller can also be used for old bearing bolt version. In such a case, the threaded bolt M 6 (Part No. 116 589 02 34 00) must be replaced against threaded bolt M 5 (Part No. 116 589 00 34 00).

These threaded bolts are also available as parts subject to wear.

8 Pull tensioning rail out in upward direction.

Installation

9 Insert tensioning rail by means of installation device Part No. 115 589 14 61 00 into cylinder head in such a manner that tensioning rail bearing bore faces bearing bolt bore in crankcase.

10 Coat bearing bolt at outer end with sealing compound "Hylomar" and knock into bearing bolt bore.

To permit engagement of locking wire in bearing bolt of 1st version, hold a piece of round material between tensioning rail and crankcase when knocking in bearing bolt.

11 Install chain tensioner. Suction oil tensioner (1st version) must be vented.

Prior to installation of pressure oil chain tensioner (2nd version), check sealing rings (6 and 14) for damage (Fig. 05-1/10).

Always replace damaged sealing rings.

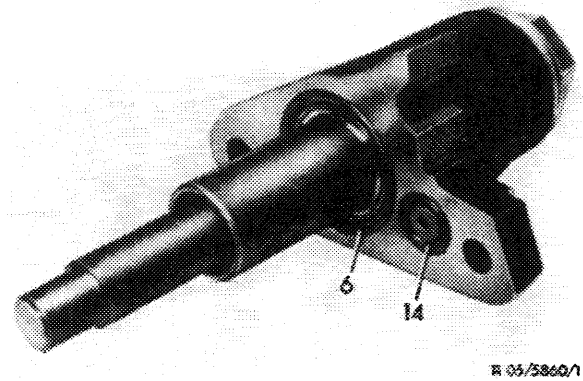

Fig. 05-1/10

6, 14 Sealing ring

12 Mount cylinder head cover, watching out for correct seat of seal.

13 Run engine and check for leaks.