

Model 230/8

The balancing disc on crankshaft is now attached by means of a hex. bolt M 18 x 1.5 x 50 (formerly M 18 x 1.5 x 45) and 4 cup springs (formerly 3 cup springs).

Standard Installation

Model	Chassis Model Designation	Chassis End No.	Engine Type Designation
230/8	114. 015	118 400	180. 954/955

The longer hex. bolt can be installed together with four cup springs also on vehicles with low chassis end No. (Fig. 03-9/1). During assembly, the cup springs must be inserted with their crowns facing the bolt head (Fig. 03-9/2).

**Caution!** The hex. bolt 50 mm long may be mounted with 4 cup springs only.

When using only 3 cup springs, the bolt would be stuck at bottom of hole. On the other hand, the former hex. bolt 45 mm long will still be installed with 3 cup springs only, since the supporting thread length would be too short for 4 cup springs.

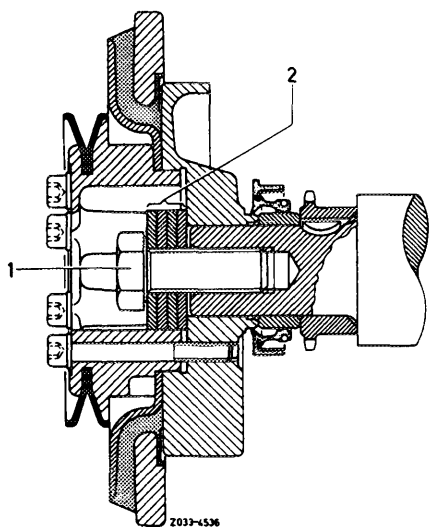

Fig. 03-9/1

- 1 Hex. bolt
- 2 Cup springs

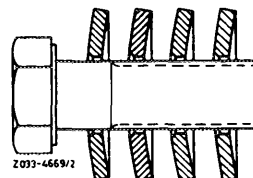

Fig. 03-9/2

Observe crowns of cup springs.

Tightening Torque

Hex. bolt (4 cup springs)	M 18 x 1.5 x 50	30 - 31.5 kpm
Hex. bolt (3 cup springs)	M 18 x 1.5 x 45	25 - 27 kpm

Spare Parts

Designation	Part No.
Hex. bolt M 18 x 1.5 x 50	000961 018020
Cup spring	127 993 00 26