

Revision: Revised.

Model 200/8 to 250 E/8

Following the installation of the manual transmission G 76 and the automatic transmission with three-planetary gear set the following changes were made on intermediate flange:

The new intermediate flange is provided with an additional hole for attaching the clutch housing (refer to arrow in Fig. 01-8/1). Bore "A" is not used on these transmissions.

The hole pattern of the remaining holes has not been changed.
The new transmissions may be assembled only with the new intermediate flange.

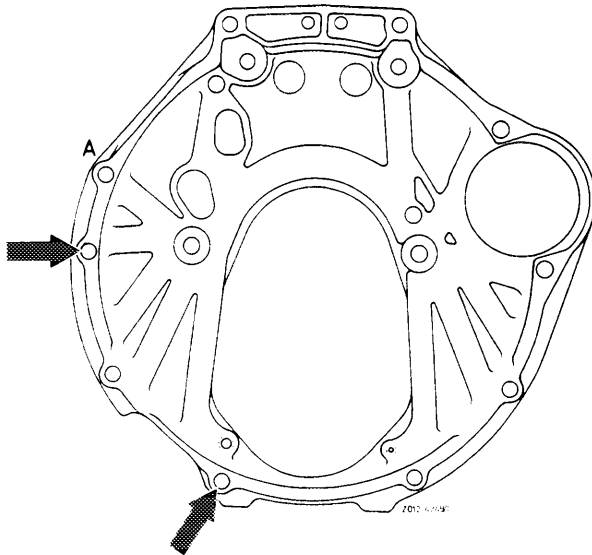

Fig. 01-8/1
New version