

General

To meet emission limits, the CIS A system has been amended and extended by lambda control which, however, does not change the basic principle of CIS A.

Lambda control keeps weight ratio air-fuel constant at approx. 14.5 : 1.

Lambda control results in the following modifications:

1. Shape of injection lines has been changed.
2. Diaphragm damper between warm-up compensator and fuel distributor is no longer installed.

In addition, the fuel distributor (5) is provided with an additional connection and a throttle (3) for timing valve (17).

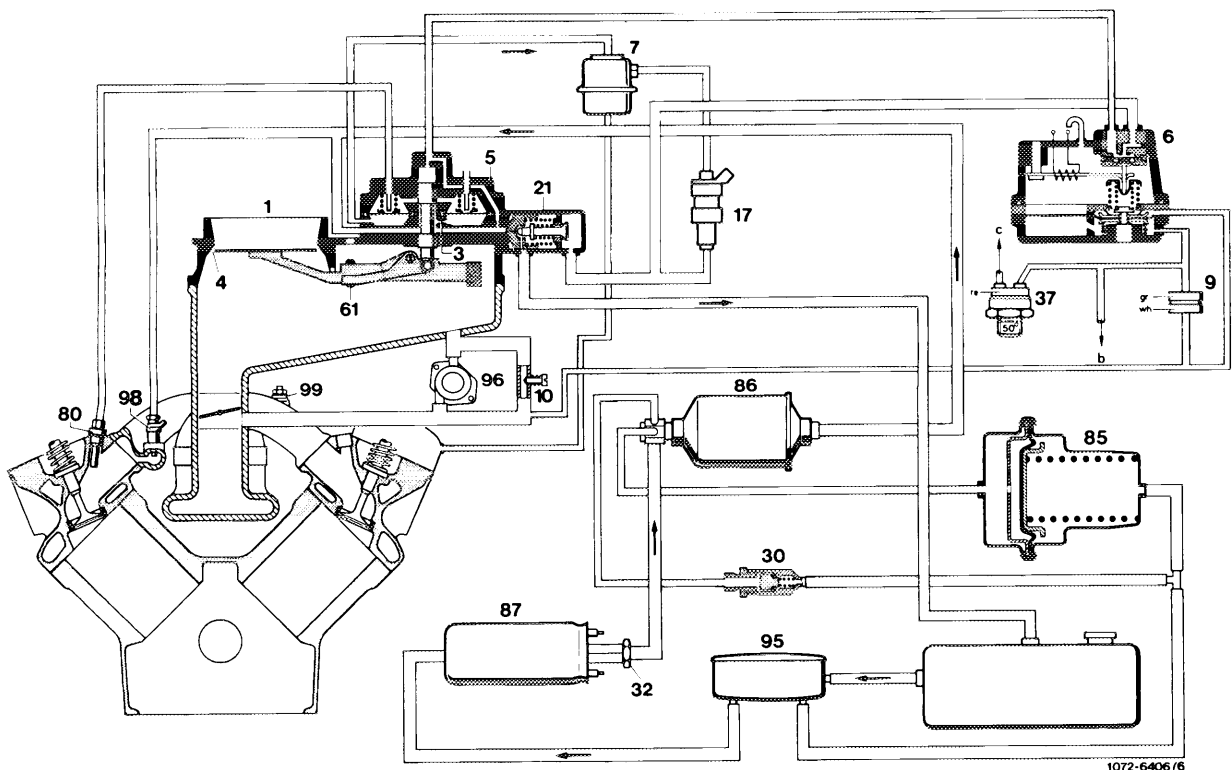

- | | | | |
|-------------------------|----------------------------------|---------------------------|---|
| 1 Mixture controller | 21 System pressure regulator | 87 Fuel pump | Color code
gr = green
re = red
wh = white |
| 3 Throttle (orifice) | 30 Pressure relief valve | 95 Intake damper | |
| 4 Air flow sensor | 32 Check valve | 96 Auxiliary air valve | |
| 5 Fuel distributor | 37 Thermo valve 50° C | 98 Cold starting valve | |
| 6 Warm-up compensator | 61 Idle mixture regulating screw | 99 Thermo time switch | |
| 7 Pressure damper | 80 Injection valve | b To ignition distributor | |
| 9 Throttle (orifice) | 85 Fuel reservoir | c To intake manifold | |
| 10 Idle speed air screw | 86 Fuel filter | | |
| 17 Timing valve | | | |

Mixture controller

The characteristic of the fuel distributor and the air funnel (cone) in air flow sensor has not been changed. The idle mixture adjusting device (1) has been attached for adjusting on-off ratio.

- 1 Idle mixture adjusting device
- 4 Air flow meter
- 5 Fuel distributor
- a Fuel forward flow
- b Fuel return flow
- c Connection timing valve return flow
- d Connection timing valve pressure side
- e Connection cold starting valve

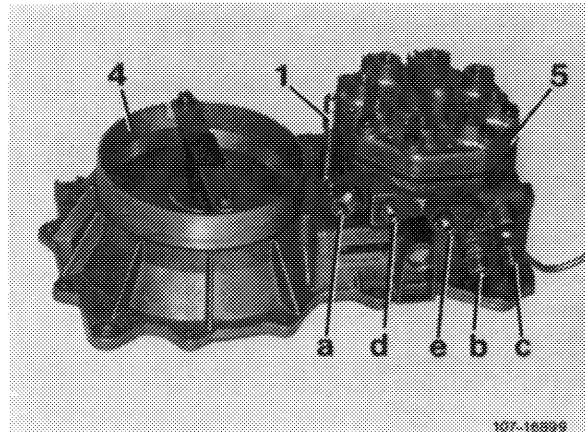

Fuel distributor

The fuel distributor is made of light alloy. A fabric diaphragm is installed between upper and lower half. The upper half of fuel distributor has 8 closing plugs with adjusting screws for differential pressure valves underneath. The differential pressure valves have been set by manufacturer to correct value and may not be adjusted during repair jobs.

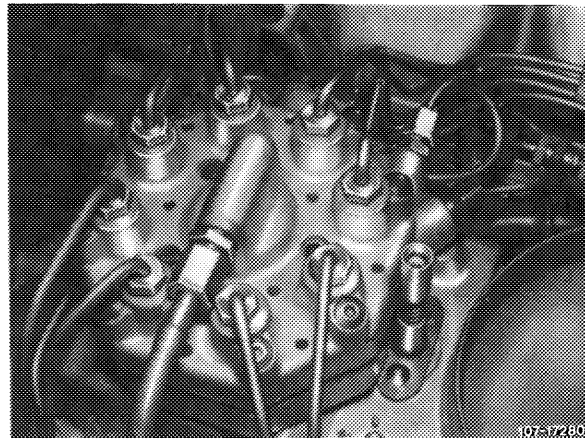

To adapt the injected fuel quantity to desired air-fuel ratio of $\lambda = 1$, the pressure in lower chambers (4) of fuel distributor is varied. If the pressure in lower chambers is reduced, the differential pressure on control slots (6) increases, which in turn increases the flow rate. To control the pressure in the lower chambers, they are uncoupled from system pressure, as compared with fuel distributor installed up to now, by way of a throttle (3), which is firmly integrated in fuel distributor. The timing valve (17) establishes the connection between the lower chambers and the fuel return flow.

When the timing valve is opened, the pressure in lower chambers can go down. If it is closed, the system pressure in lower chambers will return. When the timing valve is opened and closed in a fast rhythm, the pressure in lower chambers can be controlled according to ratio between closing time and opening time. The valve is controlled by electrical impulses from control unit.

- | | | | |
|----|--------------------|---|-------------------|
| 3 | Throttle (orifice) | a | Fuel forward flow |
| 4 | Lower chamber | b | Fuel return flow |
| 6 | Control slots | c | Leak connection |
| 17 | Timing valve | | |

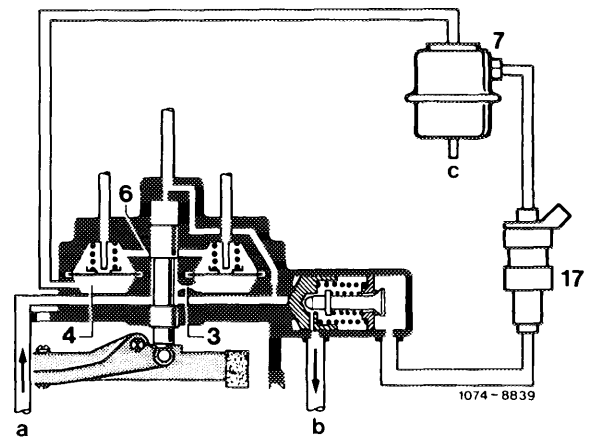

Air flow sensor

An electronic fuel pump relay handles activation of fuel pump, of warm-up compensator as well as rpm limitation of the engine and thereby replaces the safety switch on air flow meter (refer to electric wiring diagrams 07.3--165).

On model 107 the relay is located in righthand leg-room behind lateral lining in fuse box.

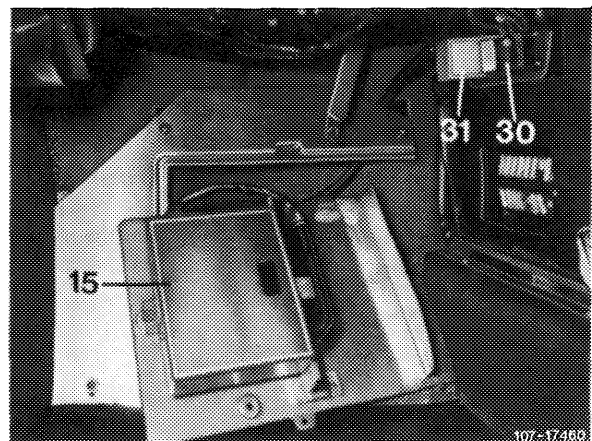

Model 107

107-17466

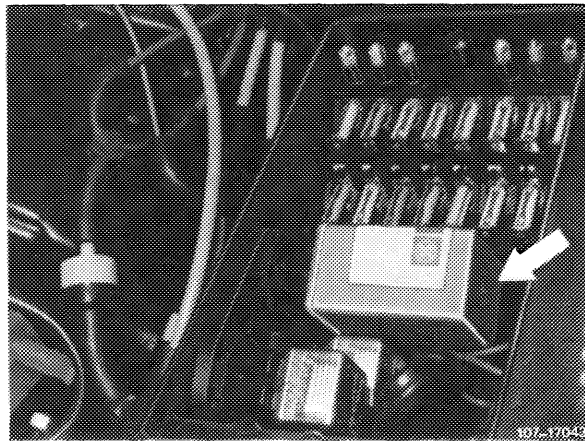

Model 116

For idle speed mixture adjustment the air flow meter is provided with an adjusting device. As a result, adjustments can be made with air cleaner mounted. The idle air mixture is no longer controlled as before by way of a CO measuring instrument, but by way of the on-off ratio of lambda control.

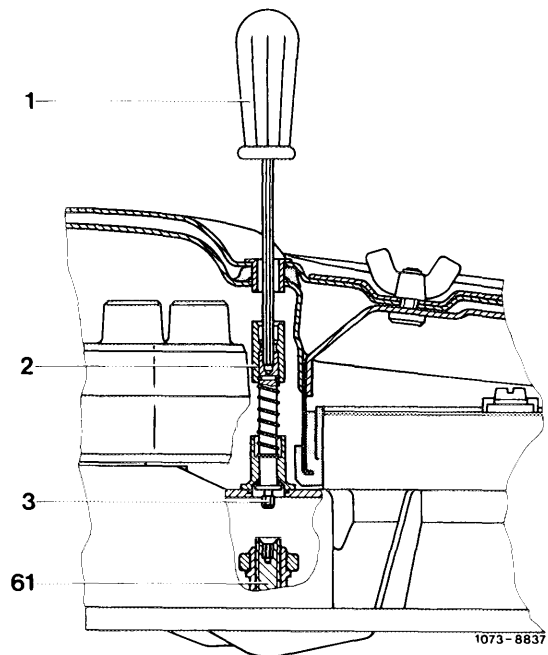

- 1 Allen wrench
- 2 Adjusting device
- 3 Hexagon
- 61 Mixture control screw

Warm-up compensator

To obtain an additional mixture enrichment in warm-up stage during acceleration, the warm-up compensator has been provided with acceleration enrichment.

Full load enrichment by way of warm-up compensator is no longer applied and is now activated via throttle valve switch.

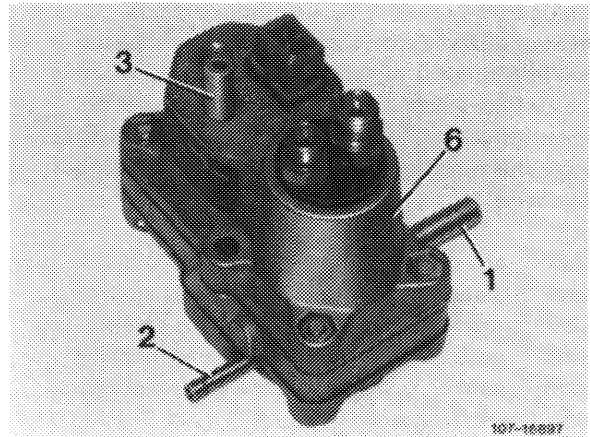

- 1 Connection upper chamber
- 2 Connection lower chamber
- 3 Vent into atmosphere
- 6 Warm-up compensator

Acceleration enrichment is controlled in dependence of vacuum below a coolant temperature of 50^o C.

Two springs are pressing on control diaphragm (71) in warm-up compensator, the outer spring (72) is firmly supported in housing and the inner spring (73) is loaded or unloaded in dependence of vacuum.

The warm-up compensator lower half has a chamber which is divided into an upper chamber (77) and a lower chamber (78) by a diaphragm. Both chambers are connected to intake manifold vacuum, with a throttle (9) located in vacuum line to lower chamber.

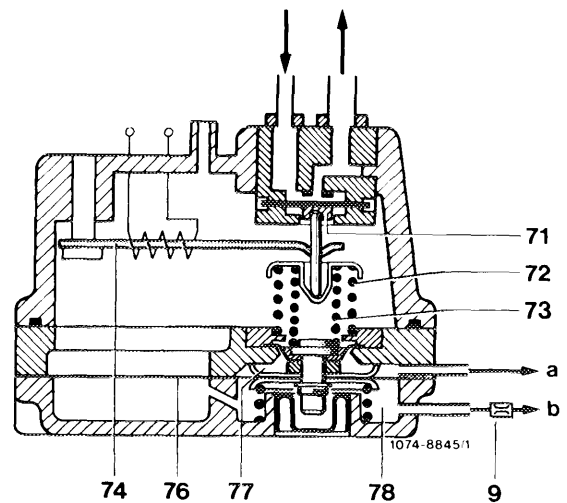

- 9 Throttle (orifice)
- 71 Diaphragm valve
- 72 Outer valve spring
- 73 Inner valve spring
- 74 Bimetallic spring
- 76 Vacuum diaphragm
- 77 Upper chamber
- 78 Lower chamber
- a Connection upper chamber
- b Connection lower chamber

At constant speed, diaphragm (76) rests against upper stop. As a result, the vacuum in upper chamber and lower chamber is the same.

Upon acceleration, the vacuum in the upper chamber will be reduced faster than that in the lower chamber under influence of throttle (9).

The inner spring will be relieved until the pressure in the two chambers is the same, and the pressure on control diaphragm will therefore be less.

Owing to the resulting lower control pressure (enlargement of outflow cross section) the control piston in fuel distributor is subject to a lower force, as a result, the air flow sensor plate will be further deflected under influence of the same air flow rate, so that a larger fuel quantity will be distributed (mixture enrichment).

Starting at a coolant temperature of 50° C the thermo-valve (37) opens. The lower diaphragm chamber of warm-up compensator is vented and the acceleration enrichment is cancelled. Both springs are pressing against control diaphragm and the control pressure goes back to its normal value.

The three functions of the warm-up compensator:

Warm-up stage

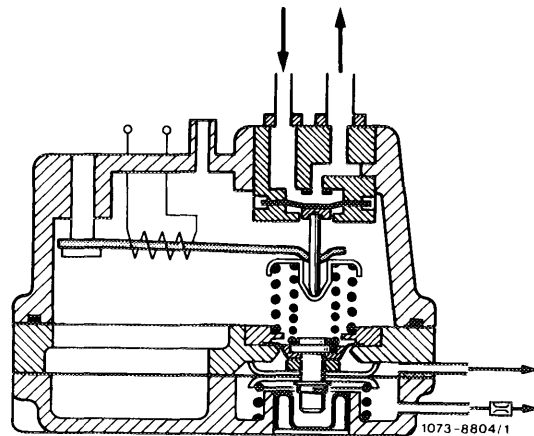

Warm-up and acceleration stage

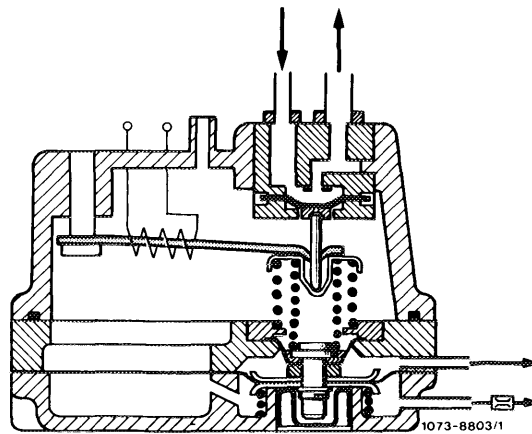

Warm-up compensator stabilized

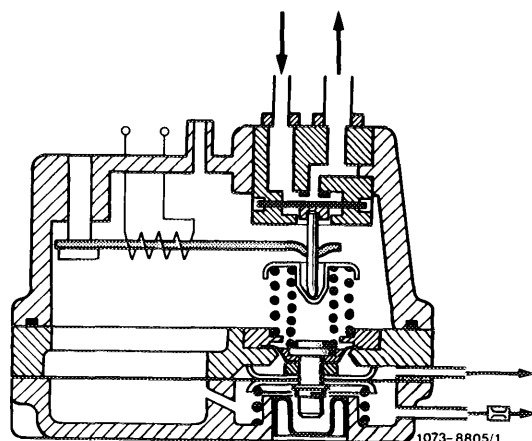

Throttle valve housing

The throttle valve housing is provided with a throttle valve switch, a vacuum connection for ignition advance, a retard bore for shutoff valve (SLS), as well as a draw-off connection for fuel evaporation.

- 1 Advance adjustment
- 2 Draw-off connection for charcoal canister
- 3 Retard bore for shutoff valve (SLS)
- 18 Throttle valve switch

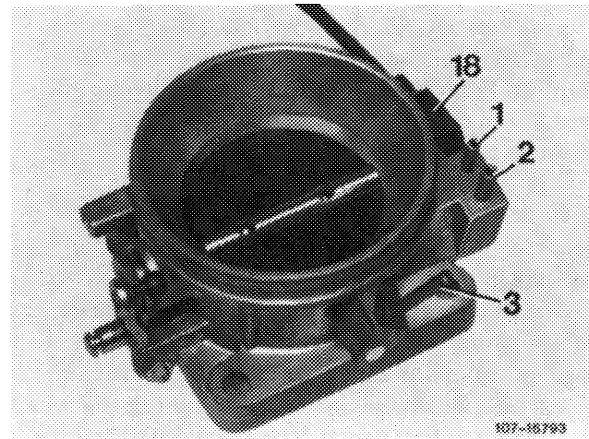

Throttle valve switch

The throttle valve switch (18) transmits a signal during idle and full load operation.

At idle, the throttle valve switch in control unit narrows the control range of lambda control to prevent rpm fluctuations at idle.

At full throttle, the throttle valve switch transmits a signal to control unit. As a result, lambda control will be switched off and the mixture will be simultaneously enriched via timing valve.

Fuel pump assembly

Layout of fuel assembly has been modified starting February 1978. A pressure compensating valve (27) has been installed at that time. The pressure reservoir and the pressure compensating valve were located in parallel with fuel filter.

- | | |
|-----------------------------------|--|
| 6 Holder for fuel pump and filter | 24 Suction damper |
| 12 Leak line | 26 Fuel pressure line |
| 14 Pressure reservoir | 27 Pressure compensating valve |
| 15 Holder for pressure reservoir | 28 Clamp for pressure compensating valve |
| 21 Filter | 31 Coupling nut |
| 22 Fuel pump | 32 Check valve |

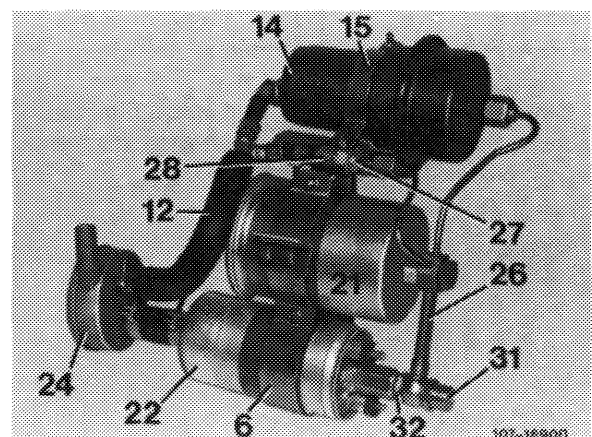

The pressure reservoir has now only one connection and is filled only slowly with fuel owing to throttle (orifice). From fuel filter the fuel flows directly into feed line to engine. As a result, the fuel pressure on injection valves will be built up faster.

In front of fuel filter is an additional pressure compensating valve, which will close in the presence of pressure in system. If the fuel volume is reduced in system when the fuel is cooling down, the pressure compensating valve will open. This will prevent a vacuum to pull the control piston in fuel distributor to full load, otherwise, the full fuel quantity might be injected for a short period during a cold start and the engine might be provided with overrich fuel.

Fuel pump

The fuel pump has a special coating on roller running surface, an exchangeable check valve (32) and a plastic sleeve to prevent contact corrosion.

The check valve has been moved outwards and can separately be replaced in the event of a breakdown.

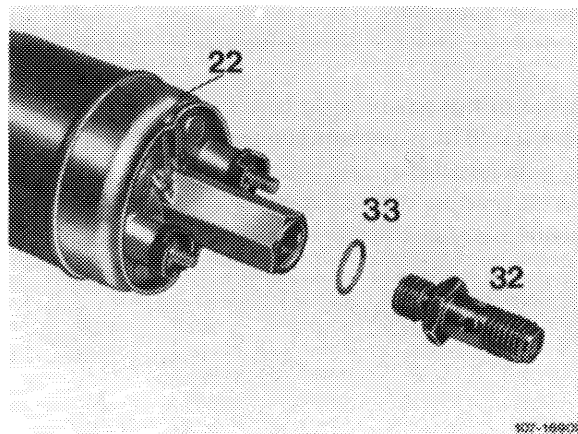

22 Fuel pump
32 Check valve
33 Sealing ring

Fuel filter

A damper is additionally integrated in fuel filter to reduce noise. To prevent contact corrosion, the fuel filter is provided with a plastic sleeve.

Repair note

When exchanging fuel filter or fuel pump make absolutely sure that the plastic sleeve is mounted between these parts and the holder. The sleeve must project on both sides of holder, since direct contact of parts with holder may lead to contact corrosion.