

Note

When renewing fuel pump make sure that a fuel pump of latest design is installed. For conversion jobs refer to job number 07.3-282 "Section B".

Fuel pump 1st version

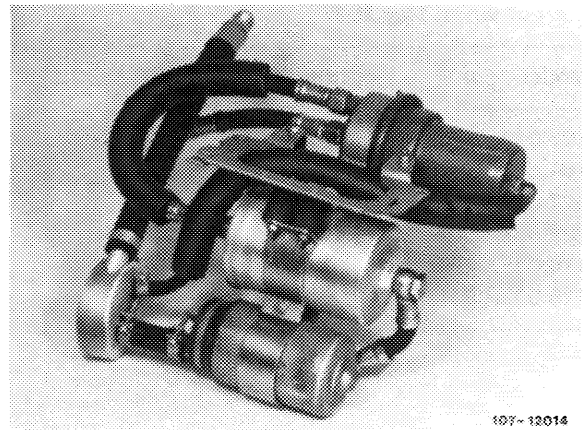
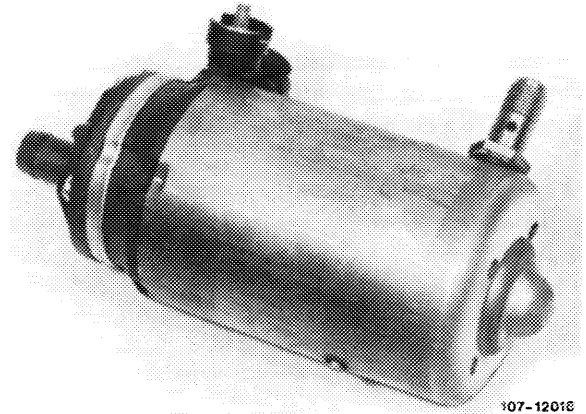

Fuel pump 2nd version

On this fuel pump the fuel connections and the electrical connections have been modified. Except for location of fuel hose (pressure end) between fuel pump and fuel filter and electrical connections, the installation position is the same.

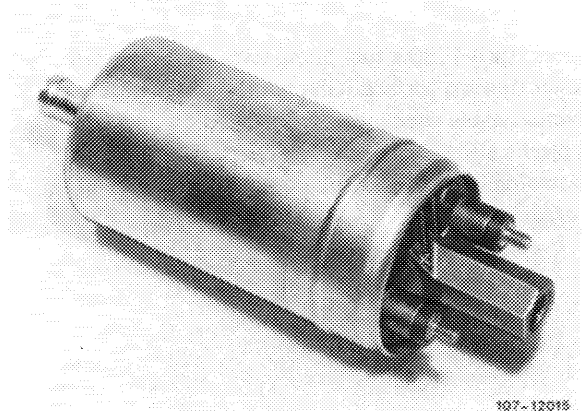

Start of series: October 1975

Model	starting chassis end No.
107.024	012079 (USA 012041)
107.044	029876 (USA 029796)
116.032/033	046201

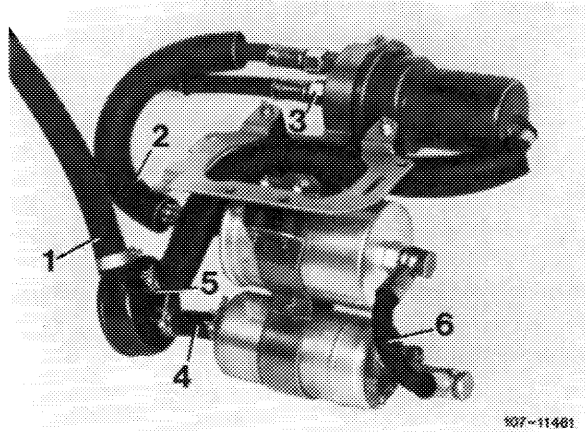

107-11481

3rd version

To keep intake characteristics constant under all climatic conditions, the intake connection has been increased to a diameter of 13 mm (formerly 10 mm).

As a result, the diameter of the connection on damper container (1) and that of fuel hose (2) had also to be changed.

- 1 Damper container
- 2 Fuel hose
- 3 Intake connection (concealed)

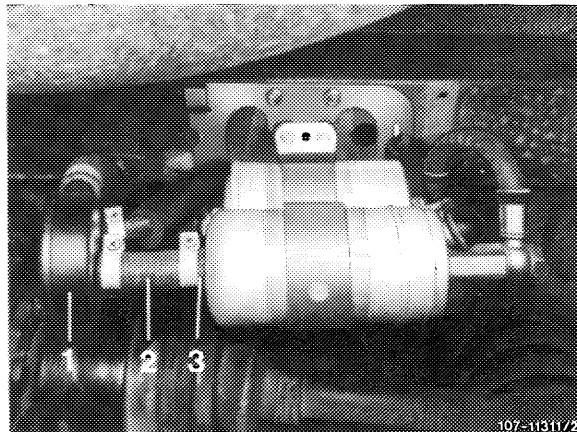

107-11511/2

Start of series: May 1977

Model	starting chassis end No.
107.023	011748
107.024	017936
107.043	012986
107.044	040364
116.028/029	040868
116.032/033	067850

4th version

Since April 1980 a fuel pump with plastic-coated roller running surface (Glycodur) and separately exchangeable check valve is installed. In addition, a plastic sleeve is mounted between fuel pump and fastening holder as a protection against contact corrosion.

- 22 Fuel pump
- 32 Check valve
- 33 Sealing ring

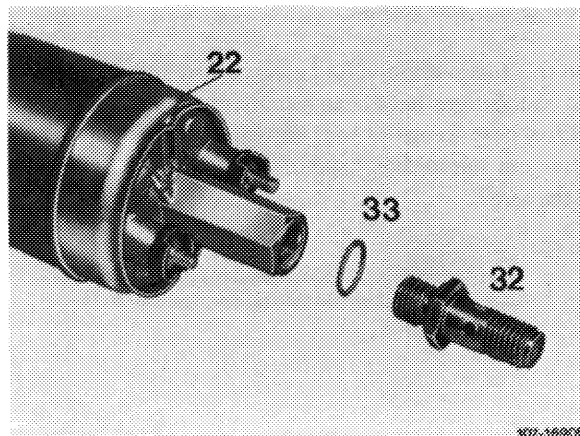

107-18306

Start of series: April 1980

Model	starting chassis end No.
107.024	030199
107.044	062340

Repair note

If in connection with complaint "Engine firing poorly when warm" an internal leak of fuel pump is found, a check valve can be subsequently mounted on former fuel pump (07.3-283).