

## 07.3–160 Checking for constant delivery of fuel distributor

### Test values

Load range	Air flow sensor plate fixed at approx. . . . . cc/min	Max. dissipation in cc/min
------------	--	-------------------------------

### Grey-iron fuel distributor

Idle	6	1.2
Partial load	30	6.0
Full load	100	10.0

### Light-alloy fuel distributor

Idle	6	0.8
Partial load	30	4.0
Full load	100	10.0

### Conventional Bosch testers and accessories

Designation	Order designation
Quantity reference measuring unit	KDJE–P 300
Tester carriage <sup>1)</sup>	M 200/2 or KDJE–W 100

<sup>1)</sup> If the tester carriage is used for quantity reference measuring unit, an additional angle plate is required. The plate can be self-made or obtained from Bosch agency.

### Note

A quantity reference measuring unit is available for checking fuel distributor in vehicle. The unit serves to measure the individual fuel quantities which are distributed by the fuel distributor to the injection valves. Measurements are on stopped engine. The operating condition (idle, partial or full load) is simulated and adjusted on air flow sensor plate by means of an adjusting device.

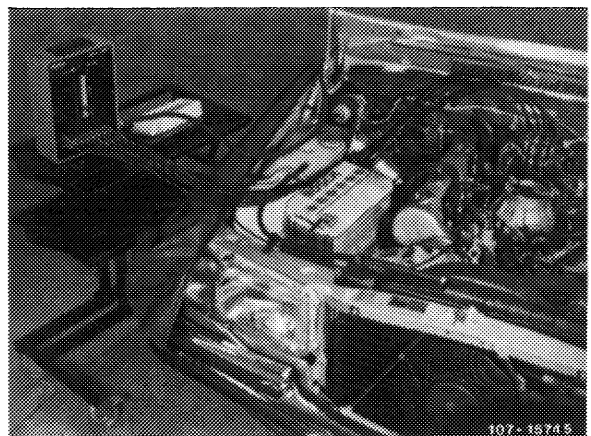

## Checking

- 1 Set up quantity reference measuring unit horizontally adjacent to vehicle (tool or tester carriage).
- 2 Remove air cleaner.
- 3 Unscrew injection lines on fuel distributor and loosen on injection valves, unscrew if required.

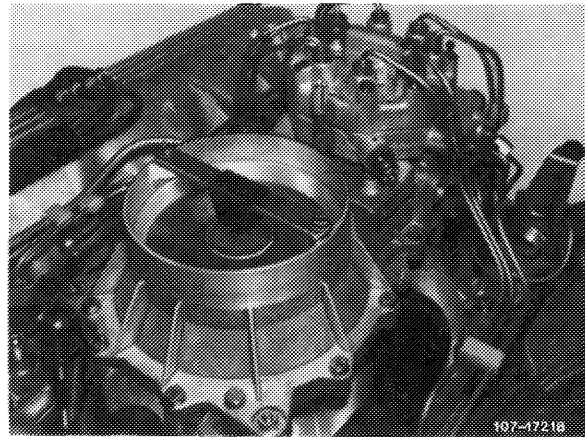

- 4 Connect connecting lines of quantity reference measuring unit to fuel distributor (sequence according to Fig.) and plug fuel return line into filler neck of fuel tank.

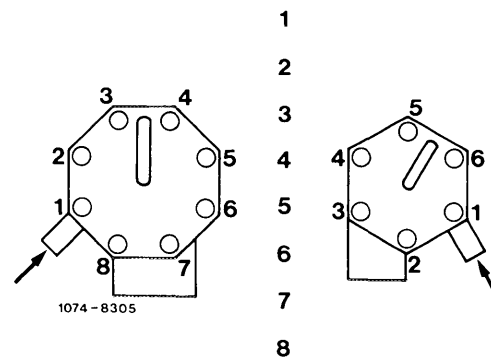

- 5 Clamp adjusting device for fixing air flow sensor plate to stop bracket of air funnel (cone).

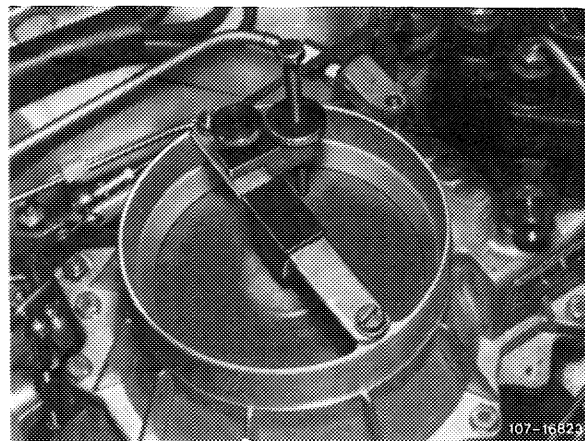

- 6 Switch on ignition.
- 7 Deflect air flow sensor plate and push individually and for a short moment buttons 1 to 8 for venting unit.
- 8 Keep one button pushed, deflect air flow sensor plate with adjusting device and fix at a flow rate of 6 cc/min (idle).
- 9 Push remaining buttons, read individual flow rates and enter on data sheet.

**Note:** Service establishments and major representatives in the Federal Republic of Germany should address orders for data sheets, print No. 800.99.472.00 to the Drucksachen-Zentrallager in Stuttgart-Untertürkheim, and general representatives in export countries to ZKD/F 2, Stuttgart-Untertürkheim. Data sheets are available in blocks of 50 sheets each.

10 Calculate difference between smallest and largest flow rate and compare with tolerance value (refer to test values).

11 For partial and full load fix air flow sensor plate as described under item 8 at a flow rate of 30 cc/min or 100 cc/min. Then also calculate difference between smallest and largest flow rate and compare with tolerance value.

12 If dissipation is outside tolerance, exchange fuel distributor.

13 Run engine and check all fuel connections for leaks.

14 Adjust idle (07.3–100).