





## 05–270 Replacement of valve stem seals

Valve clearance	with engine cold (approx. 20 °C)	with engine warm (60 °C ± 15 °C)
Intake	0.10 <sup>1)</sup>	0.15 <sup>1)</sup>
Exhaust	0.20	0.25

<sup>1)</sup> 0.05 mm higher during lasting outside temperatures below –20 °C.

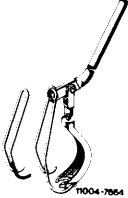
Tightening torques	Nm
Bolts for cylinder head	3
Valve adjusting screws	20–40

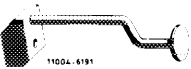
### Special tools

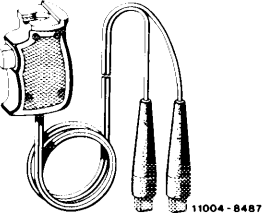
Valve spring depressor		123 589 03 61 00
Magnetic lifter for valve cone halves		116 589 06 63 00
Assembly mandrel 9 mm dia. for valve stem seal		116 589 00 43 00
Assembly mandrel 11 mm dia. for valve stem seal		116 589 01 43 00
Valve adjusting wrench 17 mm		116 589 02 01 00
Contact handle for rotating engine (component of compression meter 001 589 46 21 00)		001 589 46 21 08

### Conventional tool

Cylinder leak tester	e.g. Bosch, EFAW 210 A made by SUN, CLT 228–1
----------------------	--

## Note

Valve stem seals including assembly sleeves are supplied in repair kit.

Valve guides which are worn out at holding groove for valve stem seal must be replaced.

### Attention!

Reinstall rocker arms, thrust piece, valve spring retainers, valve springs, valve cone halves and rotocap always at the same point, if the basic position of the hydraulic compensating elements is not to be changed.

- 1 Camshaft
- 2 Rocker arm
- 3 Hydraulic valve clearance compensating element
- 4 Cylinder head
- 5 Valve guide
- 6 Exhaust valve
- 7 Valve seat ring
- 8 Thrust piece
- 9 Valve spring retainer
- 10 Valve cone half
- 11 Outer valve spring
- 12 Inner valve spring
- 13 Valve stem seal
- 14 Rotocap

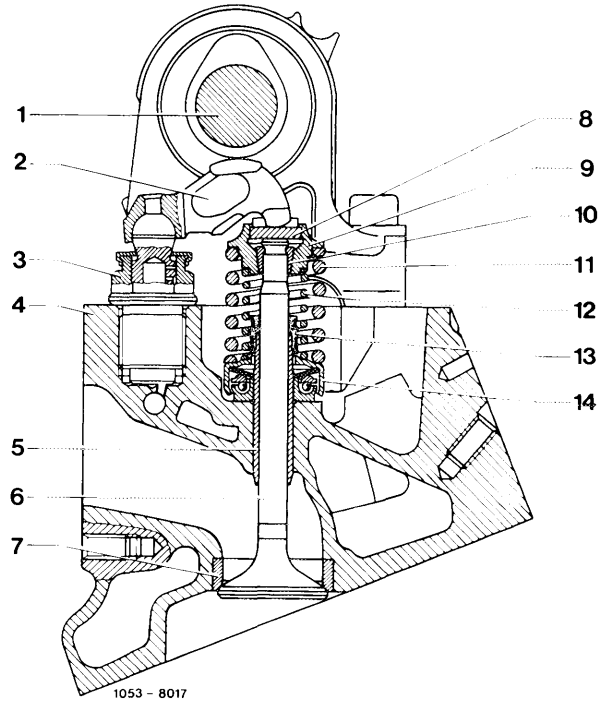

## Renewing

- 1 Remove valve springs (05–250).
- 2 Press off valve stem seals by means of a screw driver or pull off by means of pliers.

### Attention!

Do not damage valve stem and valve guide.

- 3 Debur valve stem on groove.

Renew worn out valve cone halves and spring retainers.

- 4 Check rotocap and renew, if required.

