

## 05–230 Removal and installation of rocker arms

---

Valve clearance	with engine cold (approx. 20 °C)	with engine warm (60 °C ± 15 °C)
Intake	0.10 <sup>1)</sup>	0.15 <sup>1)</sup>
Exhaust	0.20	0.25

---

<sup>1)</sup> 0.05 mm higher during lasting outside temperatures below –20 °C.

Tightening torques	Nm
Bolts for cylinder head cover	3
Valve adjusting screws	20–40

---

### Special tools

---

Valve spring depressor



123 589 03 61 00

Valve adjusting wrench 17 mm

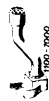

116 589 02 01 00

Contact handle for rotating engine  
(component of compression meter  
001 589 46 21 00)

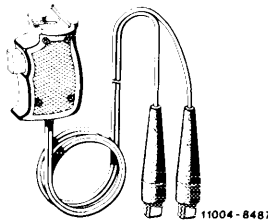

001 589 46 21 08

**Note**

Always install rocker arms at the same spot.

If the rocker arms are exchanged or renewed, check basic position of hydraulic valve clearance adjusting elements (05-213).

When installing new rocker arms, also renew pertinent camshaft.

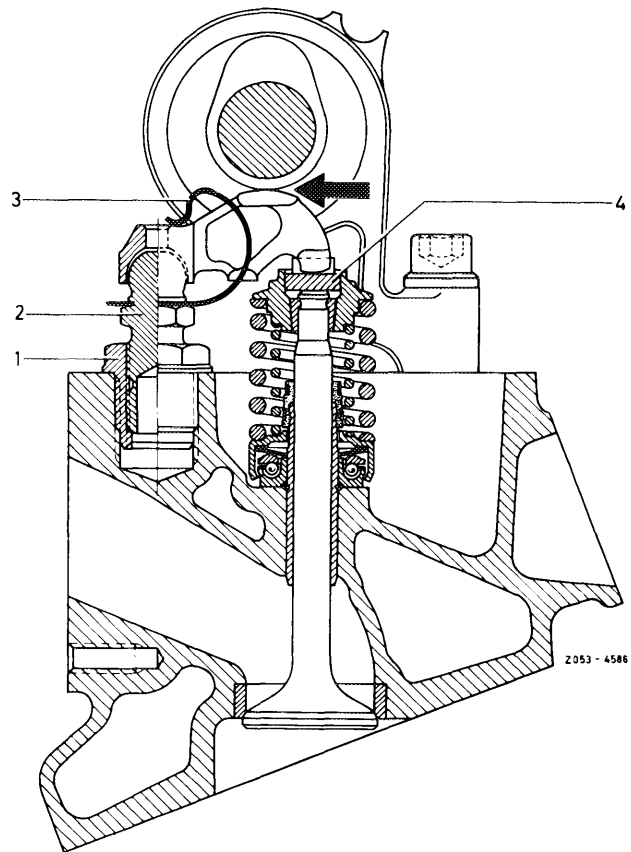

**Attention!**

With hydraulic valve clearance compensating elements use only rocker arms with chamfer (arrow).

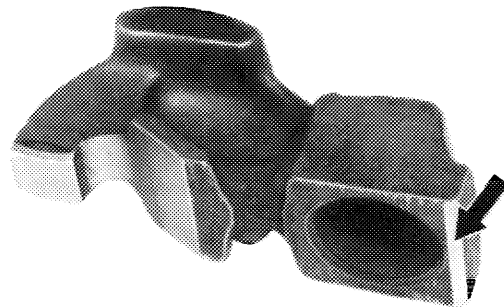

105-10604

**Attention!**

Do not interchange rocker arms and tensioning springs of engines 116 and 117 with rocker arms and tensioning springs of engine 110.

The center tensioning spring (arrow) can be used for engines 116, 117 and 110.

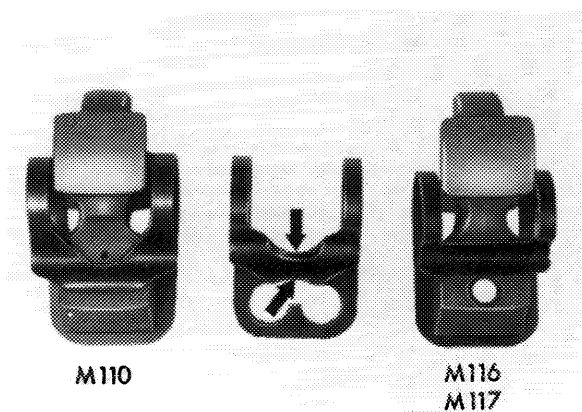

105-3034/1

## Removal

---

- 1 Remove tensioning springs with a screw driver.

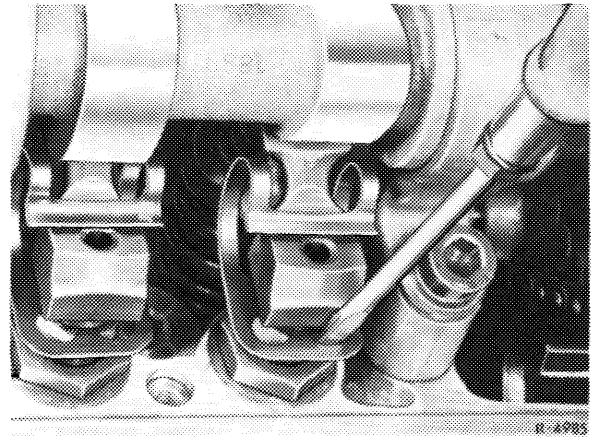

- 2 Rotate crankshaft with tool combination until cam tip is pointing upwards.

Do not rotate engine on camshaft.

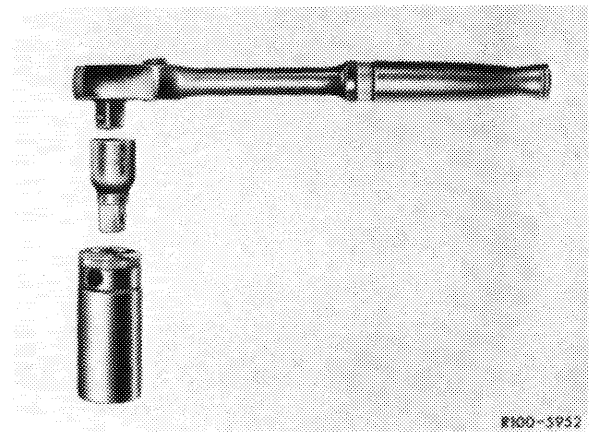

- 3 Remove rocker arm with remover and installer.

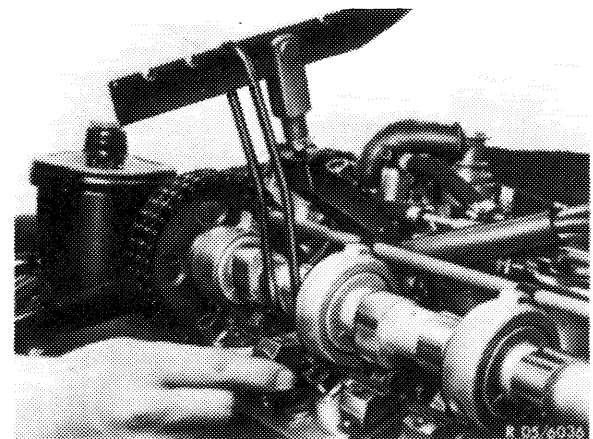

## Installation

---

- 4 Lubricate sliding and bearing surface of rocker arm.
- 5 Install rocker arm, push tensioning spring into ring grooves of adjusting screw.
- 6 Adjust valve clearance (05–210).

### Attention!

If a camshaft or a rocker arm has been renewed, check basic position of hydraulic valve clearance compensation elements (05–213).