

05–210 Inspection and adjustment of valve clearance

Valve clearance	with engine cold (approx. 20 °C)	with engine warm (60 °C ± 15 °C)
Intake	0.10 ¹⁾	0.15 ¹⁾
Exhaust	0.20	0.25

¹⁾ 0.05 mm higher during lasting outside temperatures below –20 °C.

Tightening torques	Nm
Valve adjusting screws	20–40
Bolts for cylinder head cover	3

Special tools

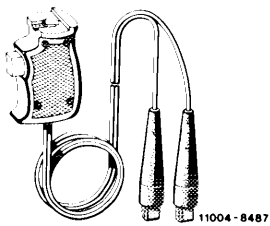
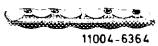
Valve adjusting wrench		116 589 02 01 00
Contact handle for rotating engine (component of compression meter 001 589 46 21 00)		001 589 46 21 08
Slip gauge holder		617 589 00 40 00
Slip gauge blades (20 each)	0.10 mm thick	617 589 00 23 00
	0.15 mm thick	617 589 01 23 00
	0.20 mm thick	117 589 00 23 00
	0.25 mm thick	117 589 01 23 00

Note

Check valve clearance with engine cold or warm and adjust, if required.

If adjustment is no longer possible, install thinner thrust piece (4). Thrust pieces are available 2.5, 3.5 and 4.5 mm thick.

Attention!

Check torque on easily turning valve adjusting screws (2). For this purpose, remove old tensioning spring (3) with a screw driver and check torque with valve adjusting wrench part No. 116 589 02 01 00 and a torque wrench. If the torque of the valve adjusting screw is below 20 Nm (2 kpm), renew valve adjusting screw (2) or threaded bushing (1) with valve adjusting screw (2).

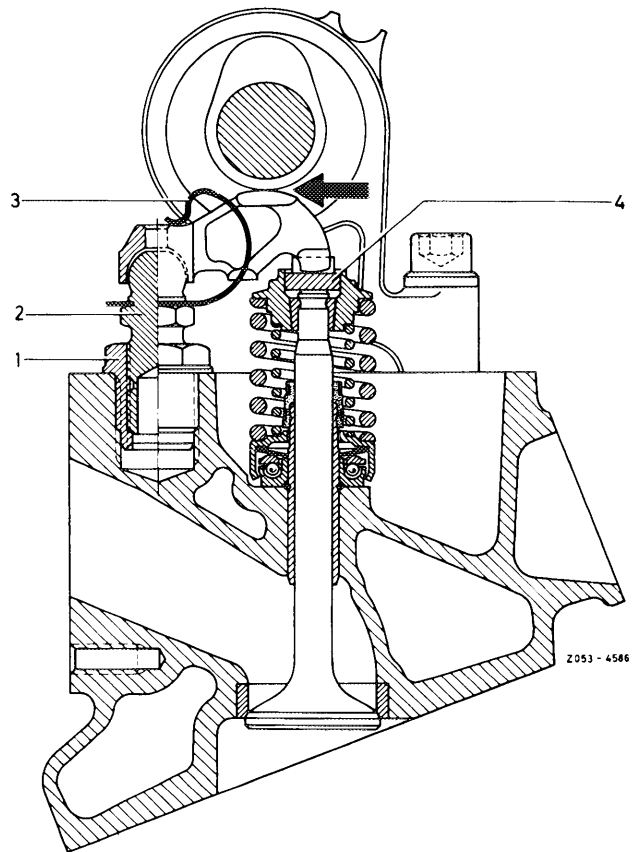

Adjusting valve clearance

1 Check valve clearance between rocker arm and camshaft, cam tip should point in upward direction.

Valve clearance is correctly set, when pulling of slip gauge blade requires some effort.

Observe layout of intake and exhaust valves.

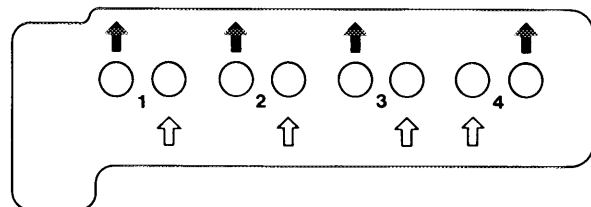

⚡ 1 5 4 8 6 3 7 2

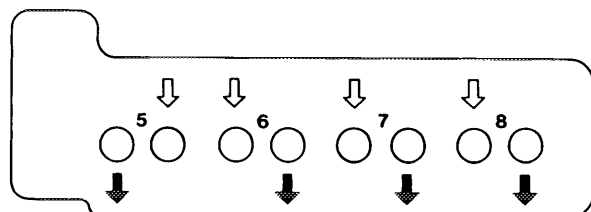

Valve layout

↑ exhaust
↑ intake

Z053-4199

The engine can be rotated as follows:

a) With tool combination at crankshaft front.

Attention!

Do not rotate engine at fastening bolt of camshaft sprocket.

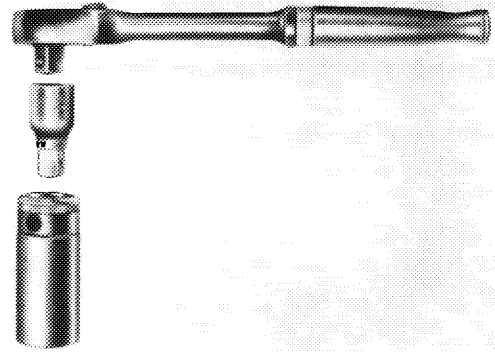

R100-5952

b) With starter and contact handle

Engines with electronic injection system

2 Connect contact handle to battery + and to starter terminal 50.

3 Disconnect cable 1 on ignition coil.

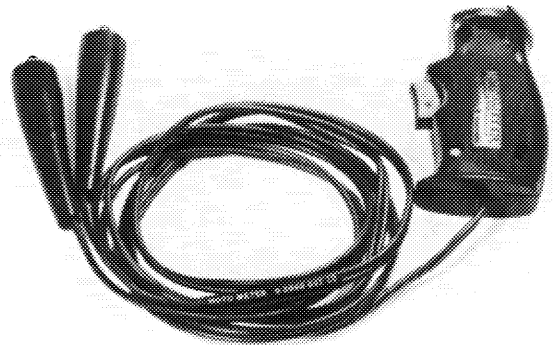

105-9061

Engines with CIS injection system

Type 116

4 Pull out fuel pump relay code No. 21 in fuse box. Connect contact handle to battery + and with the assistance of a pin to contact bushing 1 of coupling (arrow).

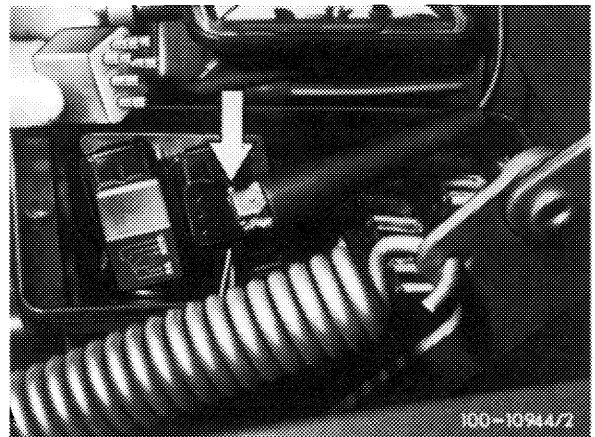

100-10944/2

Type 107

5 Disconnect cable terminal 16 (cable color red/violet) on 4-point cable connector. Connect contact handle to terminal 30 (cable color red) and terminal 50 (cable color violet).

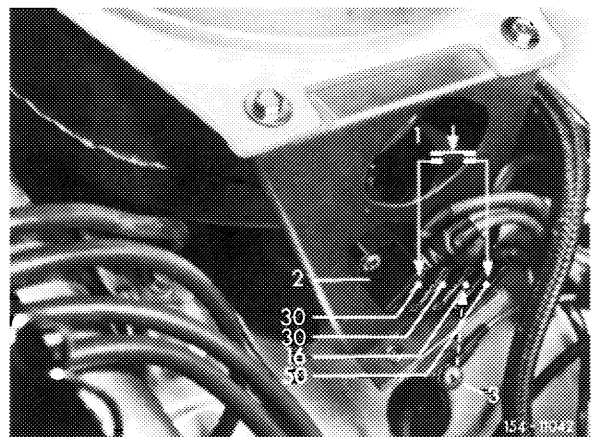

154-11142

6 Adjust valve clearance by turning valve adjusting screw with valve adjusting wrench.

7 Check tensioning springs for perfect seat.

8 Check gasket, renew according to condition.

