

01-310 Removal and installation of complete oil pan



Oil filling capacity in liters

| | | |
|-------------------------|--------------|------------|
| Model | 107 | 116 |
| Oil pan max./min. | 7.5/5.5 | |
| Oil filter | 0.5 | |
| Air oil cooler | 0.5 | 0.4 |
| Oil dipstick color code | gentian blue | light blue |

Tightening torques

| | | Nm |
|----------------------------------|------|----|
| Oil drain plug to oil pan | M 26 | 50 |
| | M 12 | 40 |
| Oil drain plug to oil air cooler | | 35 |

Special tools

| | | |
|---|--|------------------|
| Allen-box wrench 13 x 14 mm |  | 117 589 02 07 00 |
| Support for knocking-in oil dipstick guide tube |  | 117 589 00 31 00 |

Note

Since March 1972, the oil pan lower half of two-piece oil pans is installed with dimension A = 58.5 mm.

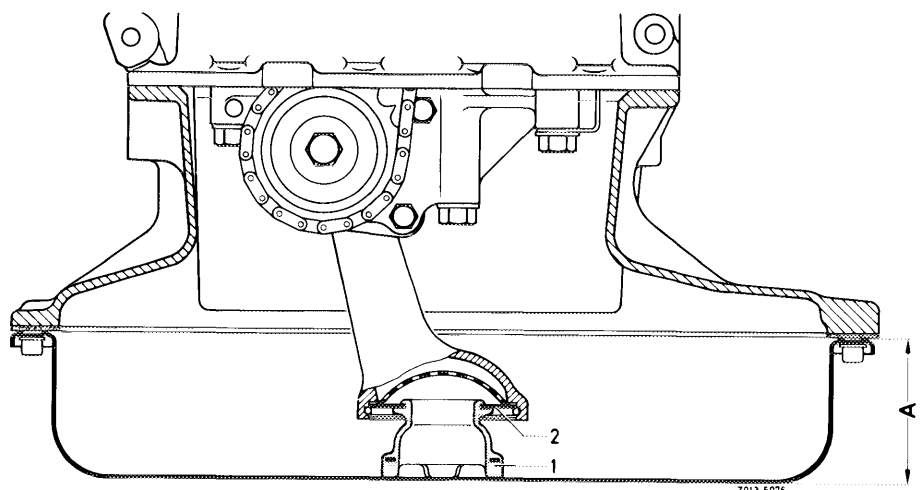

As a spare part, oil pans are supplied with 2 bores for oil dip stick guide tube. Close bore which is not required with a closing plug (arrow).

Aluminum closing plug 11.8 dia. x 10 mm
116 997 03 35

Aluminum closing plug 9.8 dia. x 10 mm
116 997 04 35

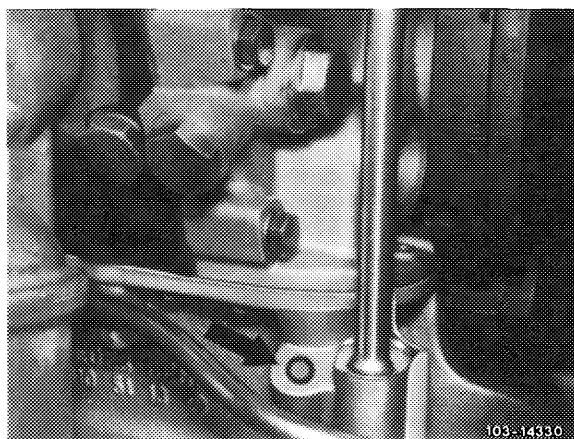

Do not mix up oil dipstick guide tubes during assembly jobs, since otherwise wrong oil levels will be indicated.

Differences are shown on drawing and in table.

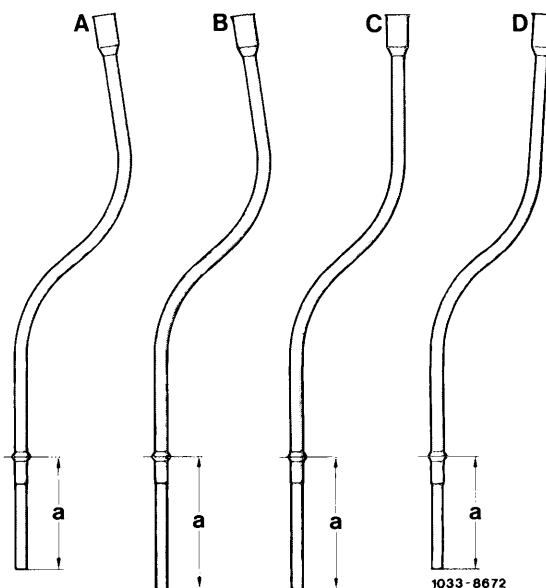

| | | | |
|---|---------------------|-------------|--------------|
| A | engine 116.985, | 117.986 | a = 125,5 mm |
| B | engine 116.984, | 117.985 | a = 135,5 mm |
| C | engine 116.960/962, | 117.960/962 | a = 135,5 mm |
| D | engine 116.961/963, | 117.961/963 | a = 125,5 mm |

An oil pan with an oil dipstick guide tube for oil suction can be installed only with a timing housing cover with offset closing plug (arrow) for oil cooler bypass valve.

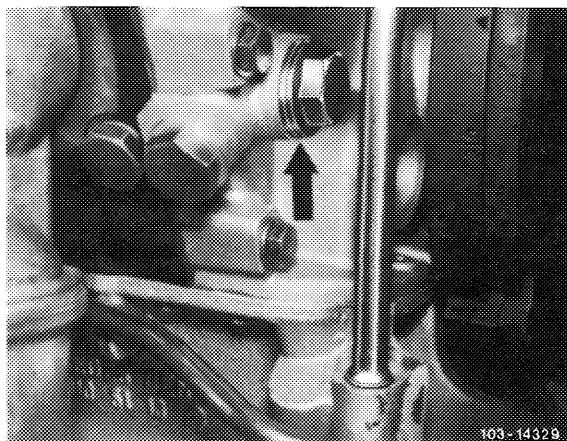

A. Model 107

Removal

- 1 Remove radiator shell and breather.
- 2 Remove front axle.
- 3 Remove refrigerant compressor with mounting bracket and tensioning roller (83–522).
- 4 Remove supporting angle bracket on transmission.
- 5 Unscrew holder for oil dipstick guide tube.
- 6 Unscrew oil pan and remove together with oil dipstick guide tube in downward direction.

Installation

- 7 Prior to installation, glue new oil pan gasket with grease on oil pan.
- 8 For further installation proceed vice versa.

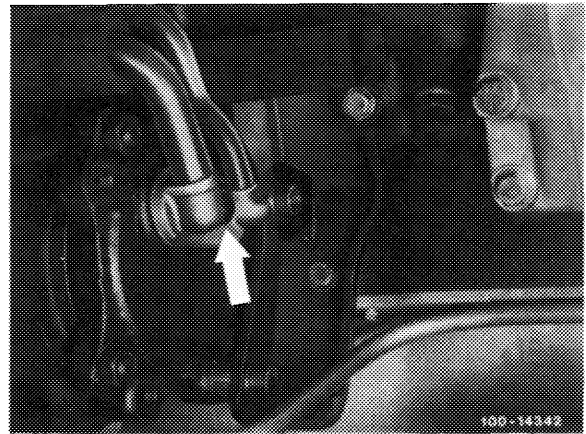

B. Model 116

Removal

- 1 Remove refrigerant compressor with mounting bracket and tensioning roller (83–522).
- 2 Remove regulating linkage.
- 3 Remove oil pan lower half.
- 4 Remove oil dipstick guide tube.
- 5 Remove oil pump.
- 6 Remove pulley for viscofan.
- 7 Remove thermostat housing cover.
- 8 Disconnect oil lines for automatic transmission
- 9 Remove supporting angle bracket on transmission.
- 10 Unscrew oil pan, turn crankshaft in such a manner that oil pan can be removed in downward forward direction.

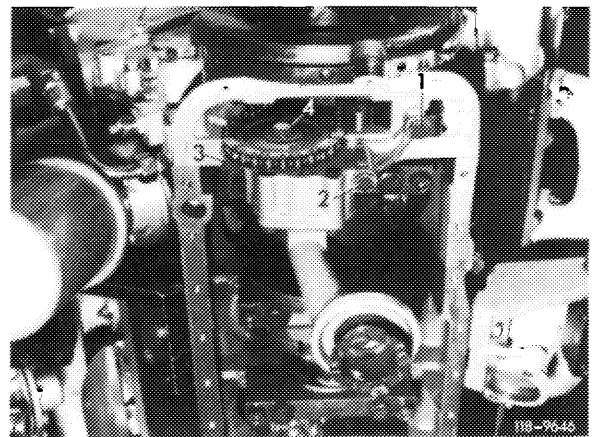

Installation

11 Prior to installation, glue new oil pan gasket with grease on oil pan.

12 For further installation proceed vice versa.