

01—220 Installation and centering of intermediate flange

Data

Permissible radial runout at fitted shoulder of intermediate flange during one full turn	0.10
Permissible axial runout at fitted shoulder of intermediate flange during one full turn	0.10
Fitted bore in intermediate flange for centering pins	12.016 to 12.043

Tightening torques

	Nm	
Fastening screws for intermediate flange	50	
Fastening screws M 8 for supporting angle on cylinder crankcase	30	
Fastening screws M 10 for supporting angle on intermediate flange	50	
Necked-down screw for driven plate or flywheel	initial torque	30–40
	angle of rotation torque	90–100°

Special tool

Dial gauge holder

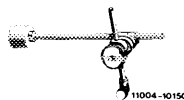

363 589 02 21 00

Self-made tool

Threaded bolt

refer to Fig., item 3

Note

A new intermediate flange must be centered.

Installing and centering

- 1 Insert intermediate flange into fitted pins (arrows) into crankcase.
- 2 Slightly tighten the four fastening screws.

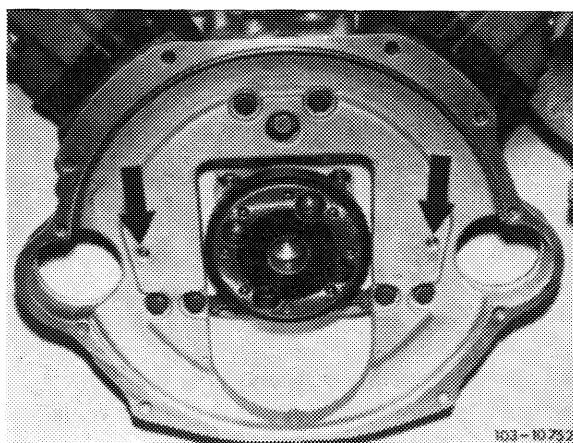

3 Screw threaded bolts into crankshaft and counterlock.

- 1 Hex. nut M 12 x 1.5
- 2 Threaded bolt 10 mm dia.
- 3 Hex. nut M 10 x 1

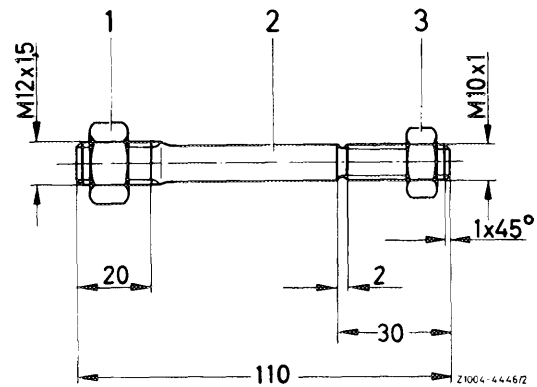

4 Attach dial gauge holder with dial gauge to threaded bolt.

5 Position feeler pin against fitted OD of intermediate flange for measuring axial or radial runout. Set dial gauge to 0.

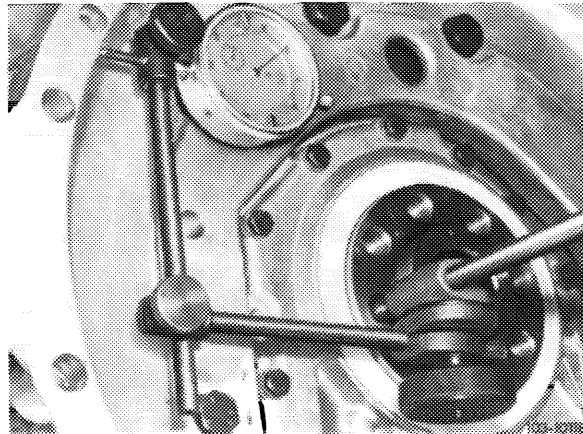

6 Turn crankshaft with tool combination in direction of rotation for one complete revolution. Radial or axial runout should not exceed max. 0.10 mm. This means that the total deflection may amount to max. 0.10 mm. If the axial runout exceeds 0.10 mm, renew intermediate flange.

Note: When rotating crankshaft, make sure that feeler pin of dial gauge is not getting stuck.

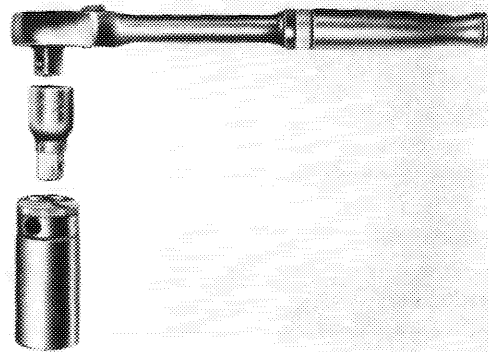

R100-5952

7 Correct radial runout by means of light blows against intermediate flange.

8 Tighten fastening screws.

Note: If the radial runout is higher than 0.10 mm, remove intermediate flange.

9 Drill both fitted bores in intermediate flange to 12.1 mm.

10 Repeat item 1–8.

11 Mount supporting angle only after the intermediate flange has been attached to cylinder crankcase.

- 1 Intermediate flange
- 2 Spring washer B 10
- 3 Screw M 10 x 28
- 4 Cyl. pin 6h 8 x 10
- 5 End cover
- 6 Washer A 6.4
- 7 Screws M 6 x 25 (5 each)
- 8 Screws M 6 x 20 (3 each)
- 9 Radial sealing ring
- 10 Cyl. pin 6h 8 x 10
- 11 Cover
- 12 Screw M 6 x 15
- 13 Cover plate
- 14 Sealing strip

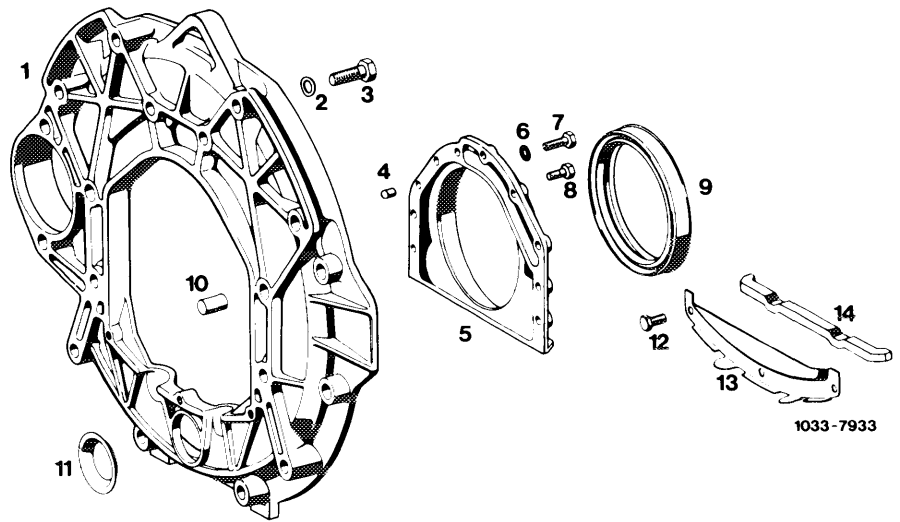

1033-7933