

07.3-130 Checking fuel pump

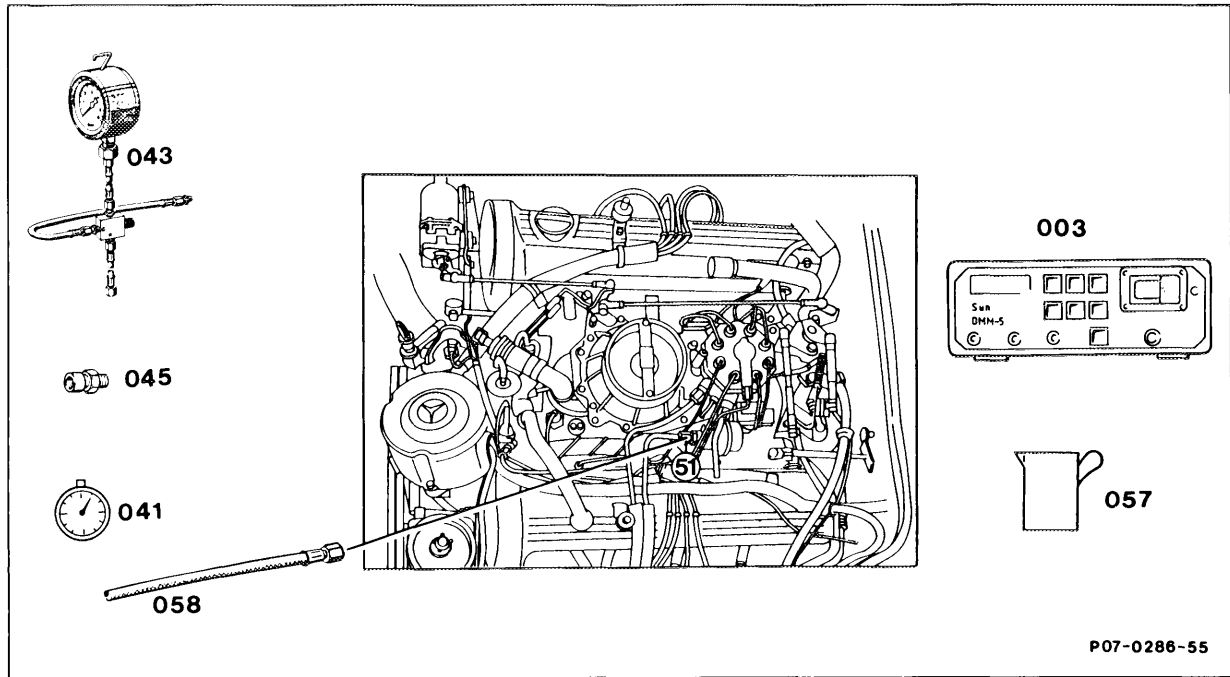

Power consumption	check. Nominal value 7-10 ampere, (figure 1). Use multimeter (003).
Fuel pressure in fuel tank	relieve by removing cap.
Fuel return line (51)	unscrew.
Fuel hose (041)	fabricate and connect to diaphragm pressure regulator.
Delivery capacity	check. Nominal value 1 liter in a maximum of 40 seconds: Use measuring cup (057), stop watch (041).
Delivery capacity	check. Nominal value 2-4 bar pressure. Use pressure measuring device (043) 103 589 00 21 00, connection fitting (045) 103 589 02 63 00.

Testing values

Fuel pump (quantity)	2
Designation	EKP 6
MB part No.	002 091 59 01 ¹⁾
Bosch No.	0 580 254 951
Measuring specifications	with engine stopped and a voltage on the supply pump of at least 11.5 volt
Rate of delivery ²⁾	Measuring point Fuel return line after diaphragm pressure regulator
	at least 1 liter in 40 seconds
Power consumption	6–10 Ampere ³⁾

1) Replacement part No. 002 091 88 01.

2) The fuel tank must be at least half full for measuring the rate of delivery.

3) Pull off connector (G3/2x1) heater coil oxygen sensor.

Special tools

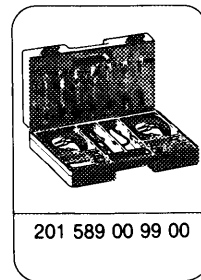
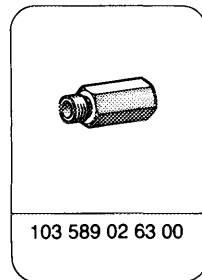
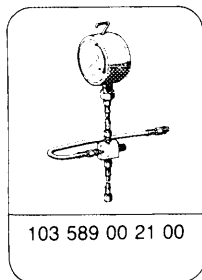

Commercially available testers

Measuring glass or measuring cup (at least 1 liter), stop watch

Multimeter

e.g. Sun, DMM-5

Shop-made tool

Fuel hose

500 mm long

Pipe with sealing flare

Union nut

M14 × 1.5

Note

Electrical wiring diagrams see 07-128.

The fuel pump operation should be heard briefly (approx. 1 second) when the ignition is switched on.

A. Rate of delivery

1 Pull off fuel pump relay (N16/4). Set multimeter to ampere. Check power consumption on jack 7 (terminal 87) and jack 8 (terminal 30).

Power consumption 6–10 ampere.

If more than 10 ampere are measured, check the following:

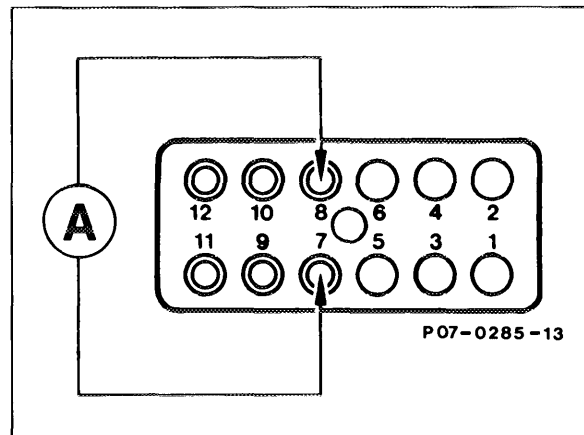

a) Pull off oxygen sensor heater coil connector (G3/2x1) and repeat measurement. In models 107 and 126 this is located in the right footwell underneath the floor panel.

Power consumption of oxygen sensor 0.5–1.3 A, check oxygen sensor if required (see 07.3-121, testing program with contact box, impulse period display 50%, test step 9.0).

b) Check fuel pressure (see section "B").

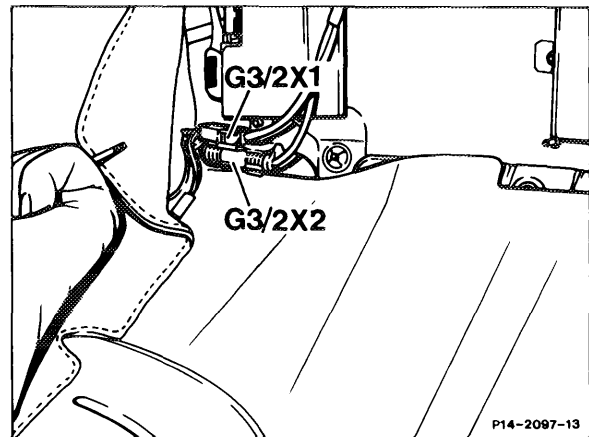

Model 126

- G3/2x1 Connector, oxygen sensor heater coil
- G3/2x2 Connector, oxygen sensor signal

2 Remove electrical wiring from multimeter. Check the fuel pump delivery rate in fuel return. Relieve fuel pressure in fuel tank by removing the cap. Unscrew fuel return line (51) from diaphragm pressure regulator and plug.

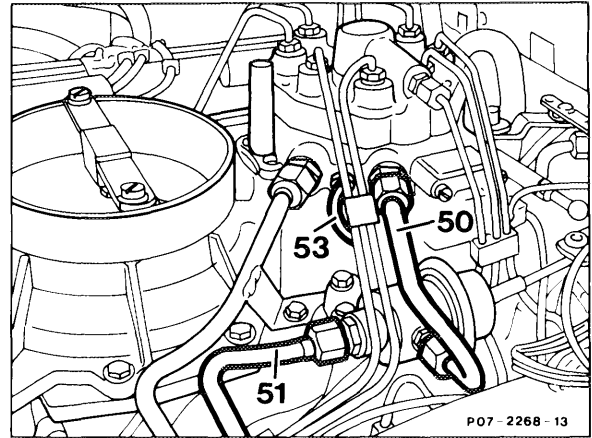

- 50 Supply system pressure
- 51 Fuel return
- 53 Return fuel distributor

3 Connect shop-made fuel hose to diaphragm pressure regulator and hold into measuring glass or measuring cup.

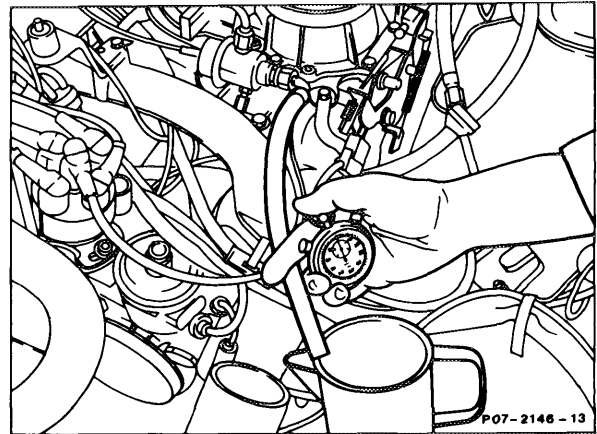

4 Bridge jacks 7 and 8 to supply the fuel pump with voltage.

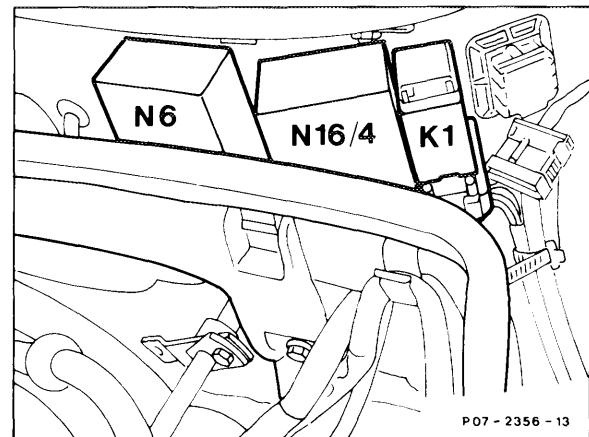

Model 126

On model 107, pull off coupling tail lamp wiring harness 8-pole (X18) in footwell left below floor panel. Connect terminal 2 with terminal 30 (terminal block next to overvoltage protection).

Model 107

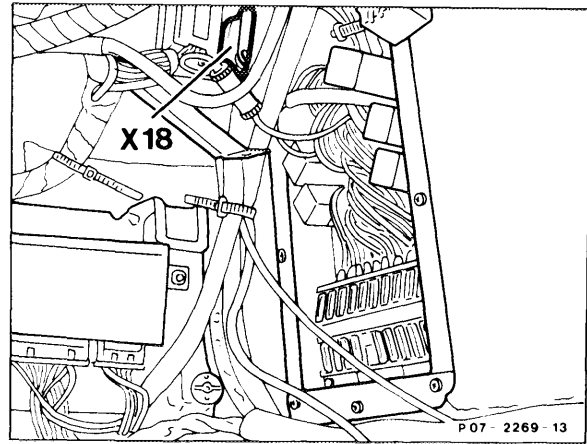

After 40 seconds or before the measuring glass/measuring cup runs over, pull off contact bridge.

Desired value:

1 liter in a maximum of 40 seconds with a minimum voltage of 11.5 volt on the fuel pump.

5 If the rate of delivery is less than 1 liter in 40 seconds, check the following points:

- a) Check voltage on the fuel pump. Nominal value at least 11.5 volt.
- b) Check if strainer in supply fitting of fuel distributor is clogged.
- c) Inspect fuel lines for constrictions (squashed lines).
- d) Pinch leak-off line between fuel storage unit and suction damper. Again check rate of delivery. If the specified rate of delivery is obtained, renew fuel storage unit.
- e) Renew fuel filter.

6 If the rate of delivery is still inadequate, determine the defective fuel pump by means of a pressure measurement (section "B").

7 Connect fuel return hose, fit relay.

B. Fuel pressure

1 Remove protective box.

2 Unscrew acorn nut from fuel pump (M3/1), connect connection fitting, part No. 103 589 02 63 00 and pressure measuring device, part No. 103 589 00 21 00 (arrow).

3 Pull off fuel pump relay and bridge the two jacks 7 and 8 (terminals 30 and 87).

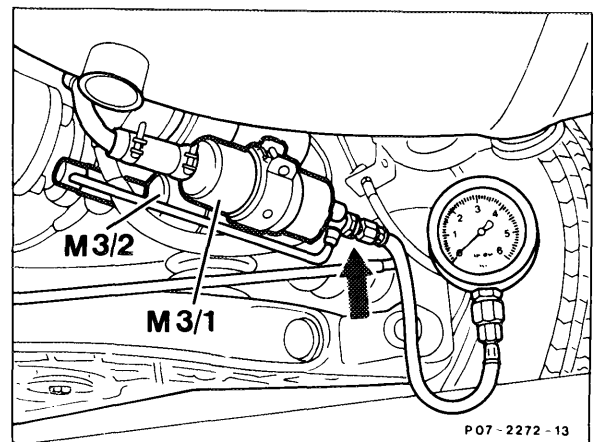

4 Read value off pressure gauge. The value must be between 2 and 4 bar. If the value is below 2 bar, the fuel pump (M3/1) is defective. If the pressure is more than 4 bar, the fuel pump (M3/2) is defective.

5 Disconnect pressure measuring device, fit acorn nut and fuel pump relay and check for leaks.

6 Fit protective box.