

# 49-100 Removing and installing exhaust system

## A. Model 107

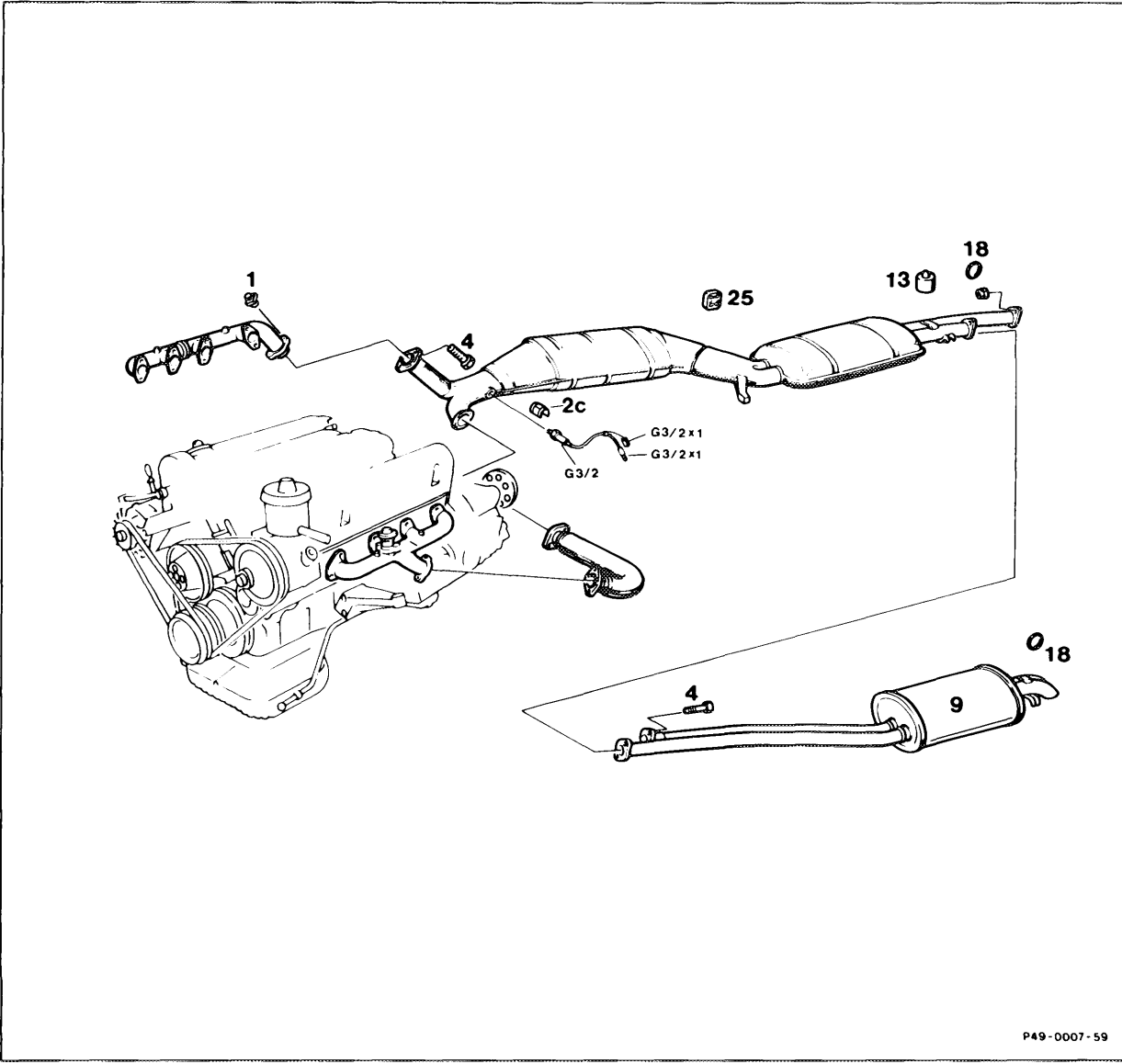

P49-0007-59

O <sub>2</sub> sensor heating coil connector (G3/2x1) and O <sub>2</sub> sensor signal connector (G3/2x2) . . . . .	detach in passenger compartment, plug together.
Heat baffle plate (2c) . . . . .	remove, fit on. Pay attention to installed position.
O <sub>2</sub> sensor (G3/2) . . . . .	unscrew, install.
<b>Installation instruction</b>	
Coat thread with paste 000 989 88 51. Ensure line is correctly laid.	
Screws (4) . . . . .	unscrew, screw in. Renew screws (4). Tightening torque 25 Nm.
Rear muffler (9) . . . . .	detach from rubber ring (18) and take off, fit on and attach.
<b>Installation instruction</b>	
Check rear muffler (9), rubber ring (18) and rubber stop (13) for signs of wear, replace if necessary.	
Rubber rings (18, 25) . . . . .	detach, attach. Examine for signs of damage and wear.
Exhaust system . . . . .	take off, install.
Riveted nuts (1) . . . . .	remove at exhaust manifold, install. Knock out riveted nuts with suitable tool (e.g.: bolt).
<b>Installation instruction</b>	
Install riveted nuts with special tool 103 589 01 39 00. Tightening torque of special tool 30 Nm.	
Exhaust system . . . . .	check for leaks with engine running.

**Special tools**

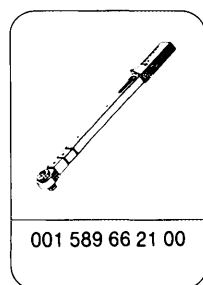
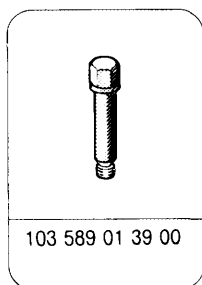

**Note**

If necessary, clean any combustion or corrosion residues off the tapered connection pieces of the pipes (2, 7) and sintered seal (5) with emery cloth.

Ensure parts are correctly installed.

Always renew self-locking nuts and asbestos or graphite gasket after being used once.

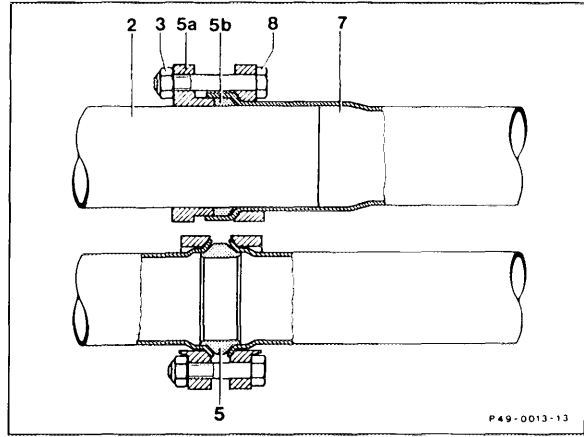

- 2 Front exhaust pipe
- 3 Self-locking nut
- 5 Sintered seal
- 5a Flange
- 5b Graphite seal
- 7 Center exhaust pipe
- 8 M8 bolt

To renew the rear muffler, place new muffler with socket fitting exactly over removed system and mark pipe length of new muffler at the removed system.

Cut through the pipe at a point 80 minus 10 mm from the marking in the direction of the rear muffler in order to obtain an insertion depth of 70–80 mm.

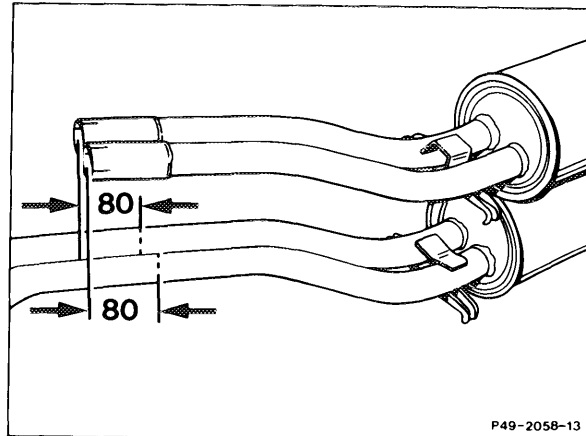

Do not tighten the flanged joint to the exhaust manifold until the complete system is attached in the rubber rings. Ensure that the front exhaust pipe is correctly located. Tightening torque of hex. bolts 20–25 Nm.

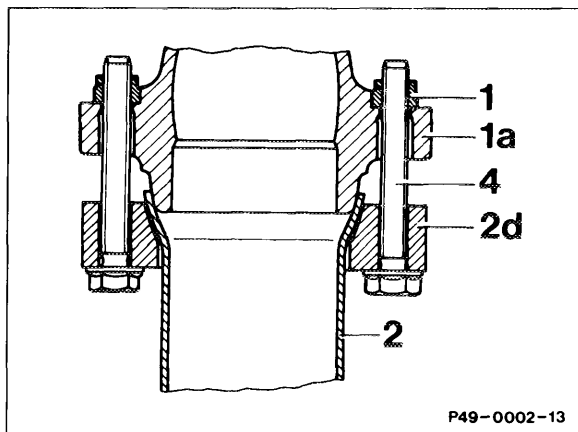

## B. Model 126

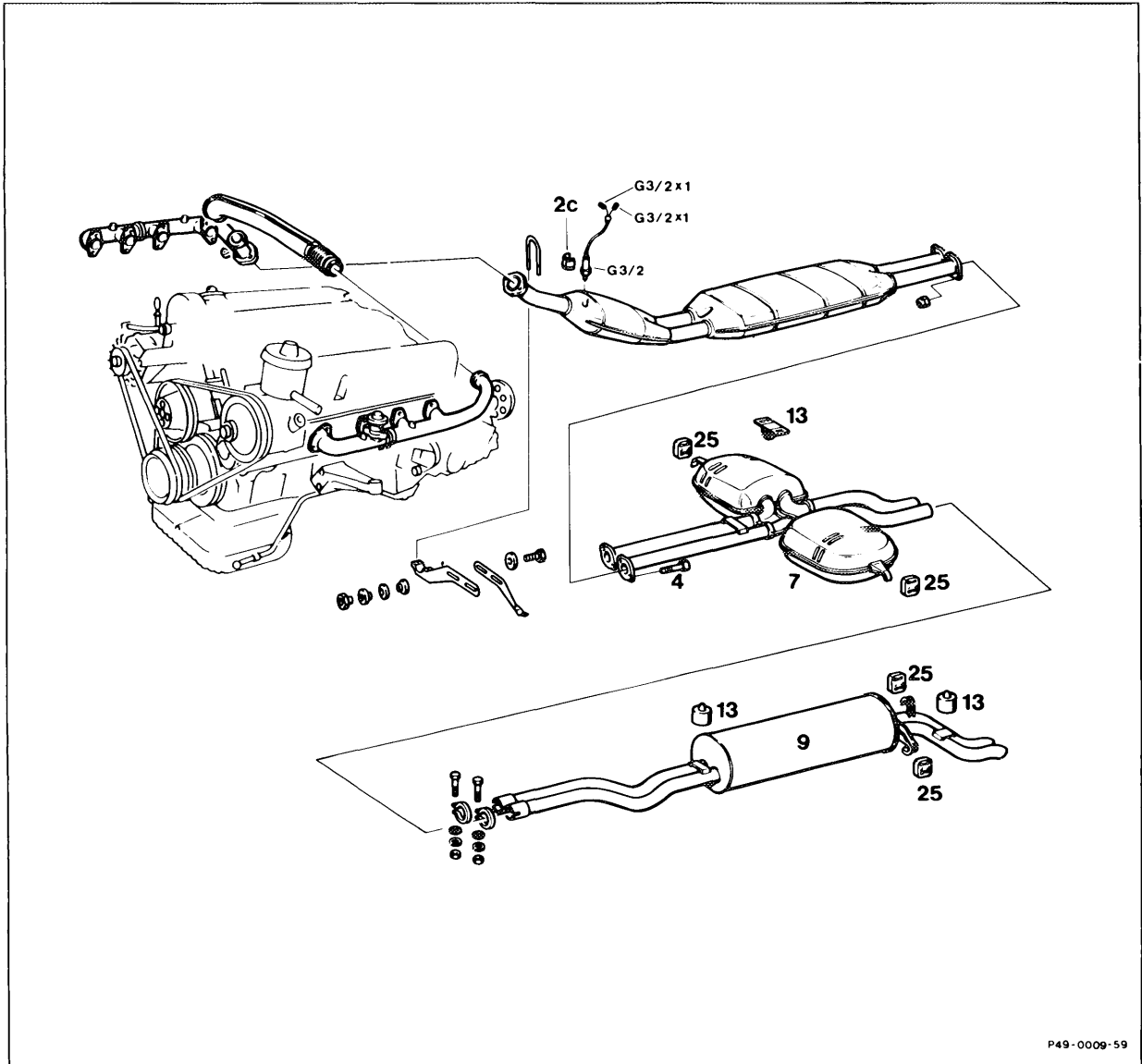

P49-0009-59

O<sub>2</sub> sensor heating coil connector (G3/2x1) and  
 O<sub>2</sub> sensor signal connector (G3/2x2) . . . . .  
 Heat baffle plate (2c) . . . . .  
 O<sub>2</sub> sensor (G3/2) . . . . .

separate in passenger compartment, plug  
 together.

pull off, fit on. Pay attention to installed position.

unscrew, install.

### Installation instruction

Coat thread with paste 000 989 88 51.  
 Ensure line is correctly laid.

Retaining bracket (6) with Belleville spring washers (17) and self-locking nuts (16) . . . . .	remove, install. Tightening torque 7 Nm.
<b>Installation instruction</b>	
Bolts (4) . . . . .	Check parts and renew if necessary. unscrew, screw in. Renew bolts (4). Tightening torque 25 Nm.
Rear muffler (9) . . . . .	detach from rubber rings (18) and take off; fit on and attach.
<b>Installation instruction</b>	
Center muffler (7) . . . . .	Check rear muffler (9) and rubber ring (18) for signs of wear, replace if necessary. detach from rubber ring (18) and take off; fit on and attach.
<b>Installation instruction</b>	
Side support (10) with bolts (11), washers (12), rubber washers (14) and nuts (23) . . . . .	Check center muffler (7) and rubber ring (18) for signs of wear, replace if necessary. remove, fit on. Tightening torque 20 Nm.
<b>Installation instruction</b>	
Exhaust system . . . . .	Check parts and renew if necessary. take off, install.
Rivet nuts (1) . . . . .	remove at exhaust manifold, install. Knock out rivet nuts with suitable tool (e.g.: bolt).
<b>Installation instruction</b>	
Rubber stop (13) . . . . .	Install rivet nuts with special tool 103 589 01 39 00. Tightening torque of special tool 30 Nm. check for signs of wear, replace if necessary.
Exhaust system . . . . .	check for leaks with engine running.

## Special tools

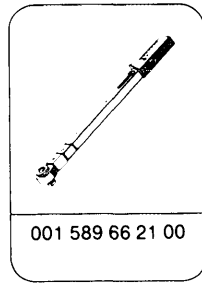
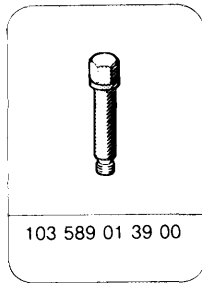

### Note

If necessary, clean off any combustion or corrosion residues on the tapered connection pieces of the pipes (2, 7) and sintered seal (5) with emery cloth.

Ensure parts are correctly installed.

Always renew self-locking nuts and asbestos or graphite gasket after using once.

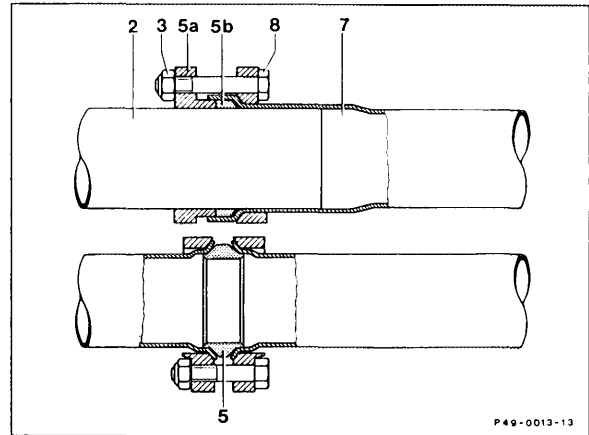

- 2 Front exhaust pipe
- 3 Self-locking nut
- 5 Sintered seal
- 5a Flange
- 5b Graphite seal
- 7 Center exhaust pipe
- 8 M8 bolt

Before inserting the rear exhaust pipe, first of all support the front exhaust pipes with the clamping bracket and side support, but do not yet tighten at this stage.

Install four Belleville spring washers on each side of the retaining bracket so that the curved faces point away from each other.

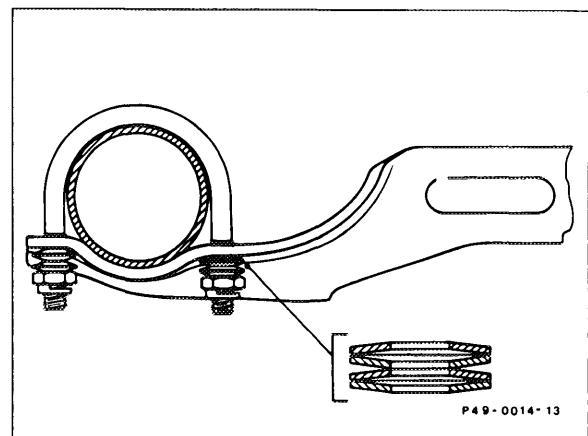

To renew the rear muffler, place rear muffler with socket joint exactly over removed system and mark pipe length of new muffler at the removed system.

Cut through the pipe 80 minus 10 mm from the marking in the direction of rear muffler to obtain an insertion depth of 70–80 mm.

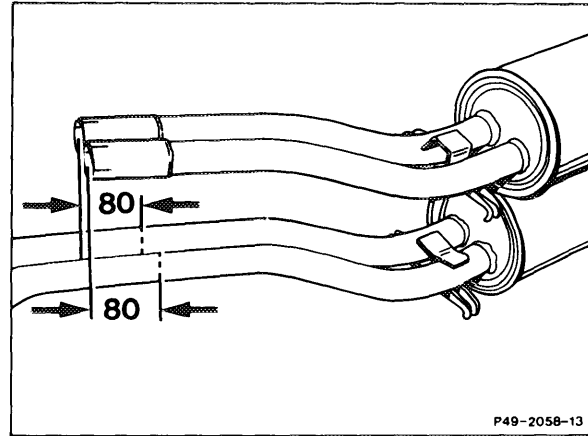

Do not tighten the flange joint to the exhaust manifold until the complete system is attached in the rubber rings. Ensure that the front exhaust pipe is correctly located. Tightening torque of bolts 20–25 Nm.

