

47-200 Function of fuel evaporation control system

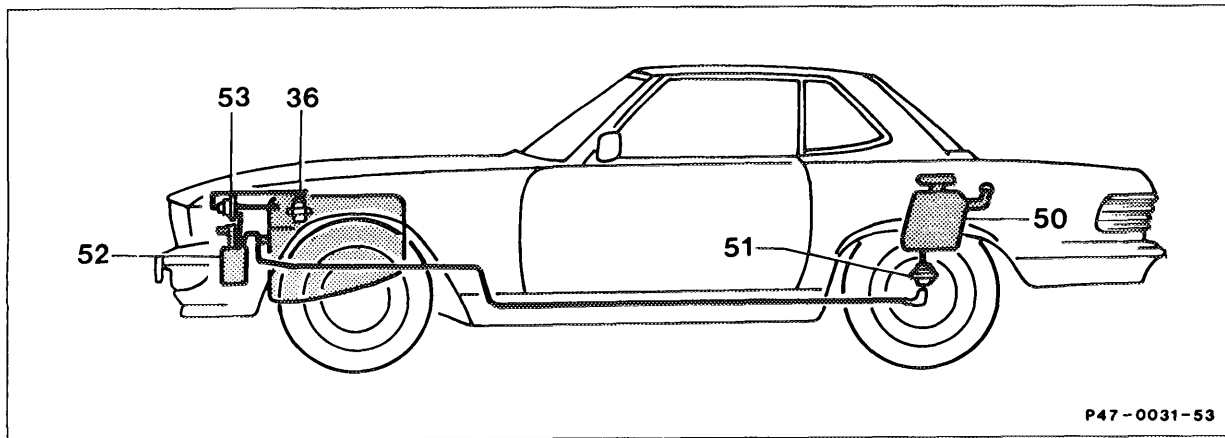

Model 107

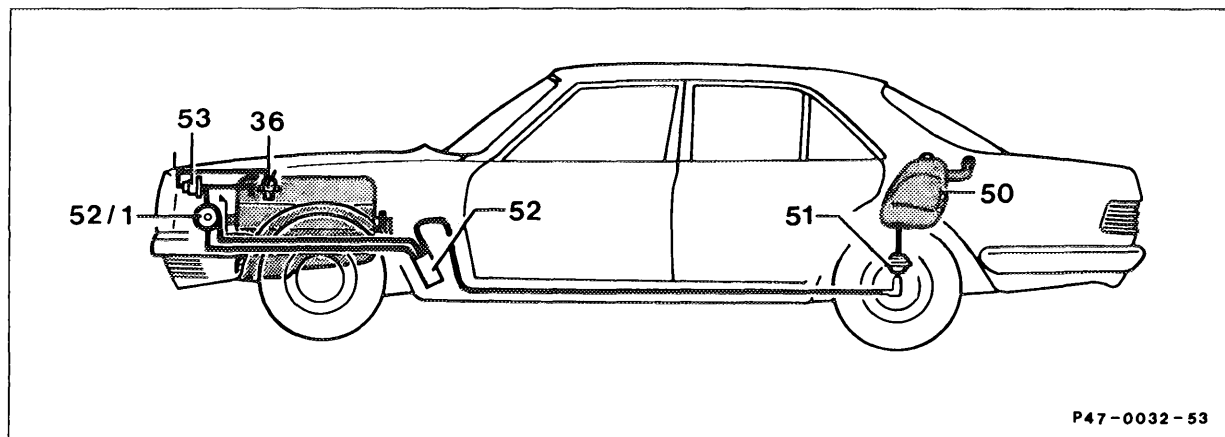

Model 126 and vehicles with ASR II

36	Thermovalve (50 °C red – starting 09/87 70 °C black/white)	52	Charcoal canister
50	Fuel tank	52/1	Boot
51	Vent valve	53	Purge valve

General

A fuel evaporation control system is installed to minimize the fuel vapors which escape to atmosphere. The fuel vapors from the fuel tank (50) are passed to the charcoal canister (52) where they are stored. Depending on the operating conditions of the engine, the fuel vapors are drawn by means of the intake manifold vacuum through the purge valve (53) and the throttle valve assembly (2) and burned in the engine. The thermovalve (36) prevents any fuel vapors being drawn off if the coolant temperature is below approx. 50 °C or 70 °C, respectively, and/or if the throttle valve is at idle stop.

Function diagram Model 107

- 2 Throttle valve assembly
- 36 Thermovalve (50 °C red – starting 09/87 70 °C black/white)
- 50 Fuel tank
- 51 Vent valve
- 52 Charcoal canister
- 52/3 Vent cap
- 53 Purge valve

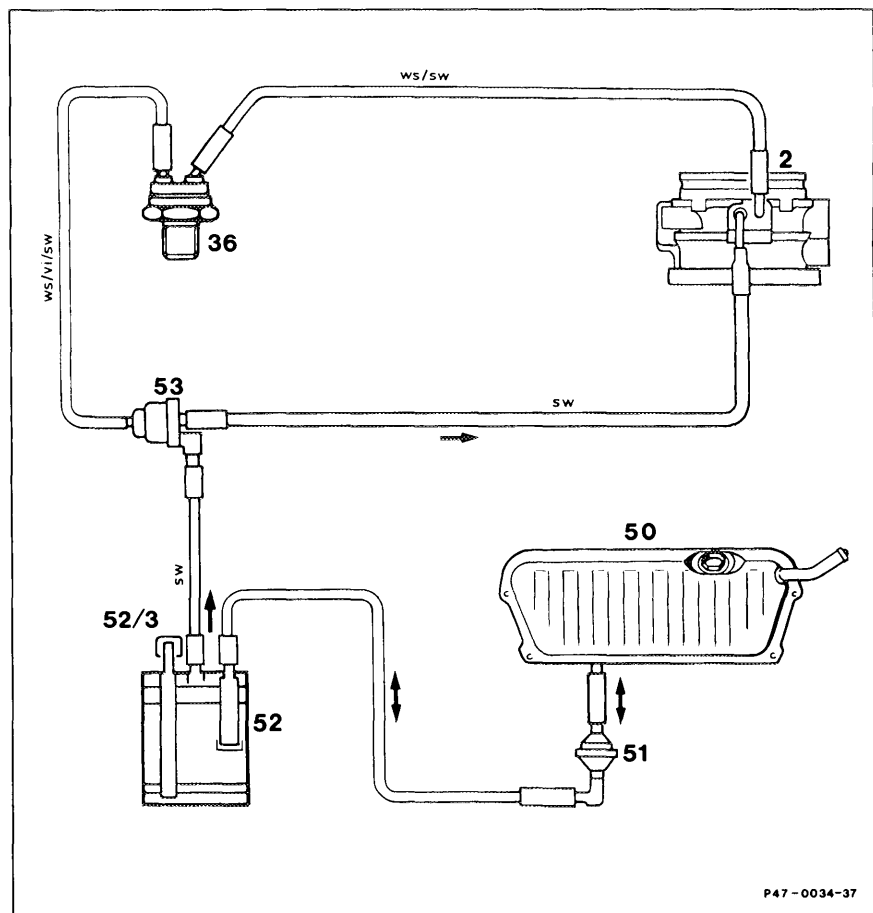

**Function diagram
Model 126**

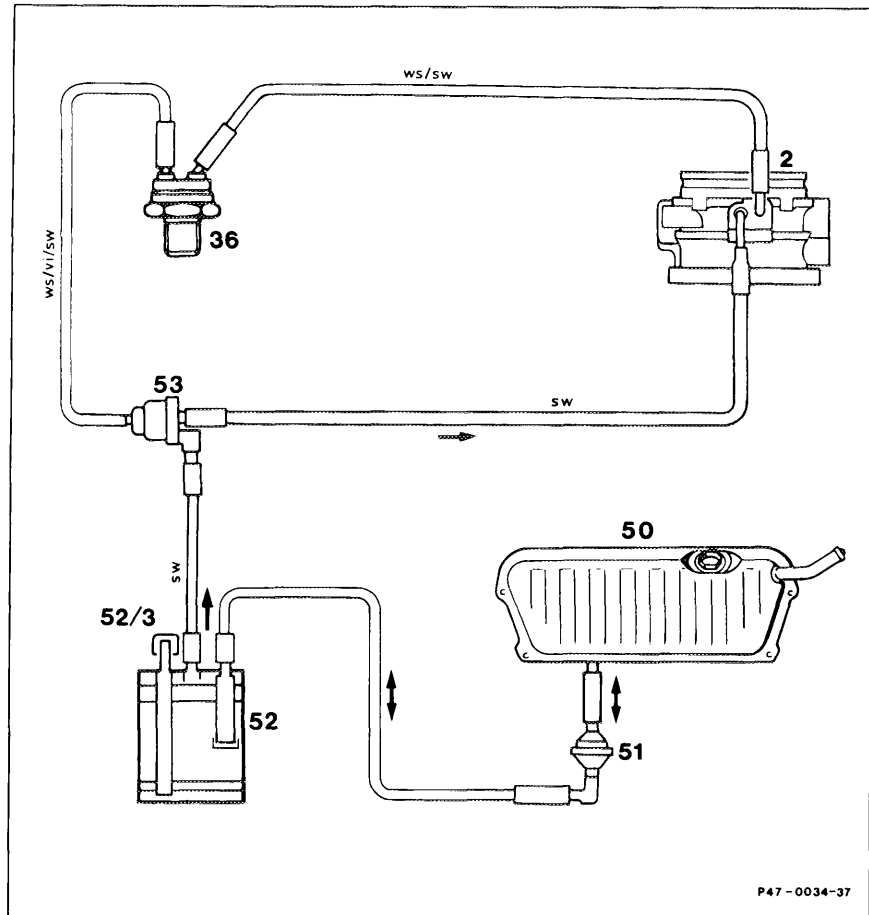

- 2 Throttle valve assembly
- 36 Thermovalve (50 °C red - starting 09/87 70 °C black/white)
- 50 Fuel tank
- 51 Vent valve
- 52 Charcoal canister
- 52/1 Boot
- 53 Purge valve

P47-0034-37

Function

If an pressure of 30–50 mbar is reached in the fuel tank, the vent valve (4) opens and the fuel vapors flow to the charcoal canister.

Vent valve (51, see Function diagrams) to charcoal canister open.

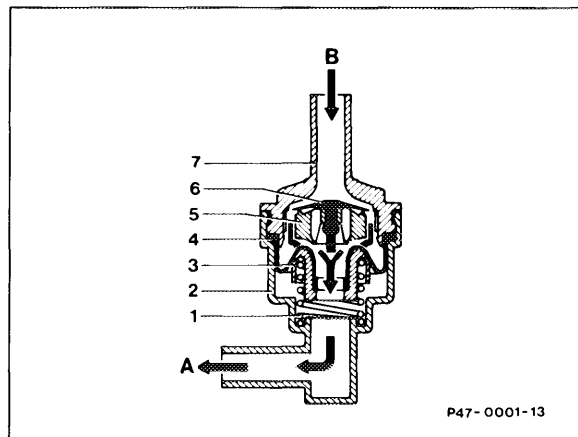

P47-0001-13

- 1 Compression spring
 - 2 Valve housing
 - 3 Spring plate
 - 4 Vent valve
 - 5 Valve plate
 - 6 Air admission valve
 - 7 Connection fitting
- A Charcoal canister connection
B Fuel tank connection

If a vacuum of 1–16 mbar is produced in the fuel tank, the air admission valve (6) opens. As a result, air or fuel vapors are drawn in through the charcoal canister.

Vent valve (51, see Function diagrams) to fuel tank open.

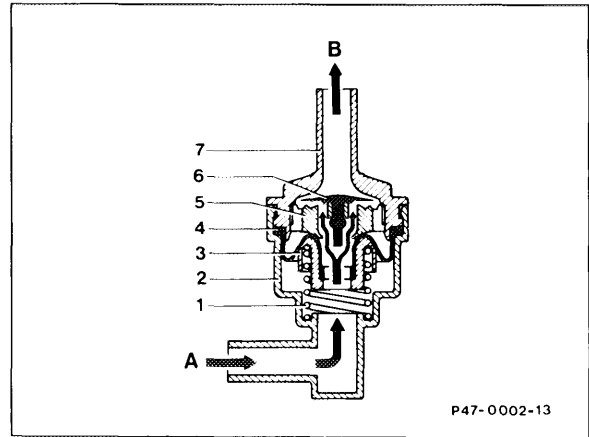

P47-0002-13

When the engine is running and the coolant temperature is more than 50 °C or 70 °C, respectively, the intake manifold vacuum when the throttle valve is just slightly open, flows through the thermostatic valve to purge valve (connection C).

Thermostatic valve 50 °C red, 70 °C black/white

- 1 Bimetal plate
- 2 O-ring
- A To purge valve
- B To throttle valve assembly

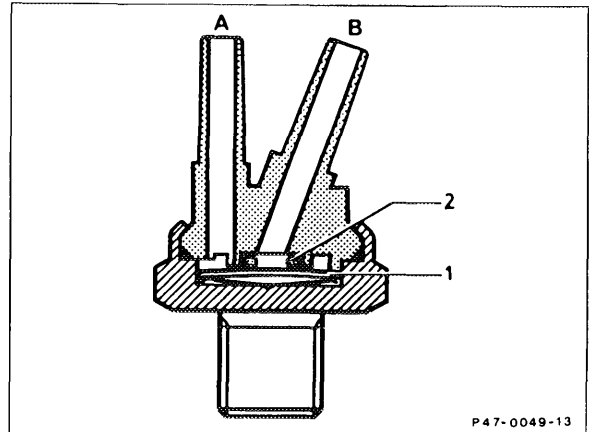

P47-0049-13

The diaphragm (4) is pulled up against the spring force if the vacuum is 20–35 mbar or more. The passage from connection A to connection B is opened.

Purge valve (53, see Function diagrams) open.

- 1 Compression spring
- 4 Diaphragm
- A To charcoal canister
- B To throttle valve assembly
- C Vacuum connection

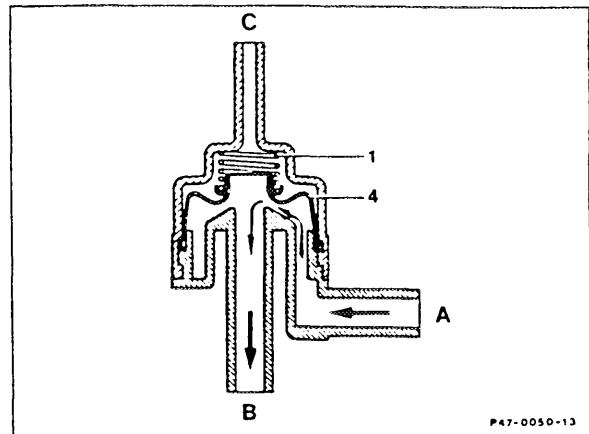

P47-0050-13

If the throttle valve is closed further, the suction port (c) in the throttle valve assembly is activated. As a result, the fuel vapors stored in the charcoal canister are drawn off. The activated charcoal is purged.

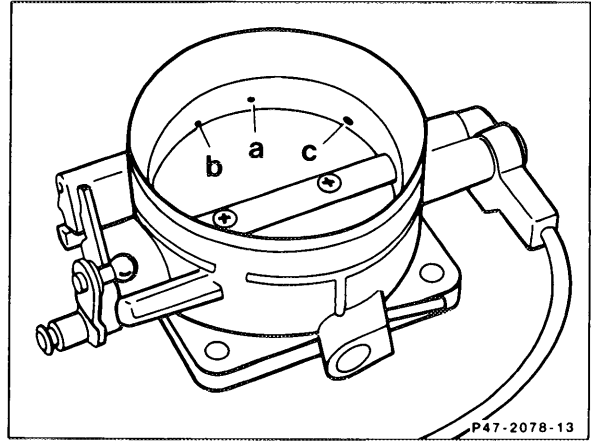

P47-2078-13

- a To EGR thermostatic valve
- b To fuel evaporation control system thermostatic valve
- c To purge valve
- d To EGR vacuum control valve

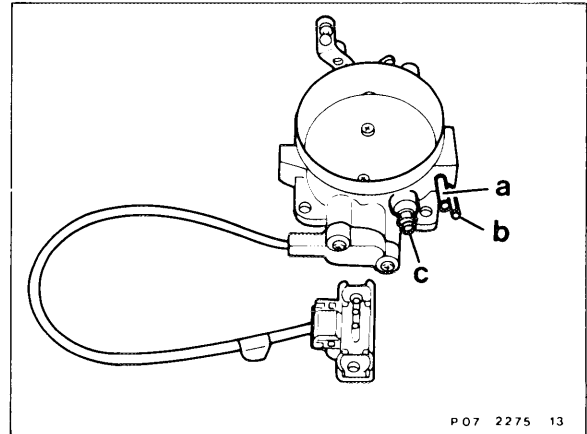

P 07 2275 13

Note

To prevent any enrichment of the mixture from the charcoal canister, disconnect the purge line to the throttle valve assembly at the purge valve (78) and seal it when performing work such as "Adjusting idle speed" or "Checking, tuning engine".

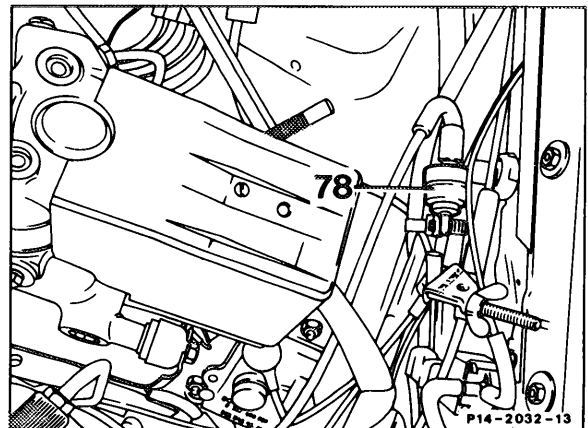

P14-2032-13