

Timing in degree (°) crank angle, with 2 mm valve lift

Camshaft code number ¹⁾ left/right	Engine	Engine special version No.	Inlet valve opens ATDC ²⁾
02/03	117.960	—	12° (10°)
04/05	117.961	—	20° (18°)
08/09	116.964 116.965 117.962 117.963 117.964 117.965	012.468/01	22° (20°)
14/15	117.963	012.406/10	18° (16°)
16/17	117.968	012.480/01	17° (16°)
18/19	117.967 117.968	012.468/05 012.468/06 012.468/14 012.468/15	27° (26°)
20/21	116.965 117.965	—	21° (20°)
24/25	117.968 RÜF		17° (16°)
26/27	117.967 117.968 CAT	012.468/05 012.468/06 012.468/14 012.468/15	27° (26°)
60/61	116.960 116.961 116.962 116.963	012.406/03 012.406/04 012.406/07 012.406/08	12° (10°)
62/63	116.960 116.961 116.962 116.963	012.406/01 012.406/02 012.406/05 012.406/06	24° (22°)
70/71	116.962 116.963 116.964 116.965	012.468/03 012.468/04	16° (14°)

¹⁾ The association of camshaft code number can be taken from the spare part microfilms.

²⁾ With new timing chains and a running time of below 20 000 km, the timing for the right-hand camshaft must be adjusted according to the values in brackets.

Tightening torques		Nm
Bolts for cylinder head cover		3
Bolts for camshaft sprockets M 14 x 1.5 x 40		100
Cylinder head bolts	1. Initial torque	30
	2. Final torque	60
Fastening screws for camshaft bearings on cylinder head		50

Special tools

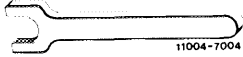
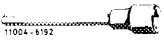
Spring compressor for valve spring		123 589 03 61 00
Retaining wrench for camshafts		116 589 01 01 00
Screwdriver insert 8 mm, 1/2" drive, 130 mm long		000 589 33 07 00

Conventional tool

Screwdriver insert 8 mm, 1/2" drive, 52 mm long	e.g. Hazet, D-5630 Remscheid Order No. 986-8
---	---

Note

Pay attention to the association of camshaft code number relative to the respective engine (see table). The camshaft bearing journals can be ground, repair stage camshaft bearings are available (05-225).

If a camshaft needs to be replaced, it is necessary to replace the corresponding rocker arms as well.

The camshaft bearings of the engines 116.96 and 117.96 may be used on the cast iron engines 116.98 and 117.98.

Removal

- 1 Remove cylinder head cover.

For this purpose disconnect fuel lines on left-hand cylinder head cover (arrows).

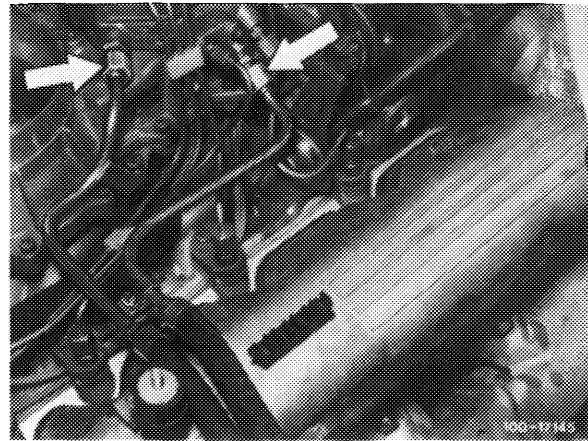

- 2 Disconnect relay for fuel pump so that no fuel runs out of fuel line when the engine is cranked with the starter motor.

- 3 The engine can be rotated by connecting terminals 30 and 50 so that the respective cam tip is in an upward position for removing the rocker arms. For this purpose disconnect terminal 16 (arrow).

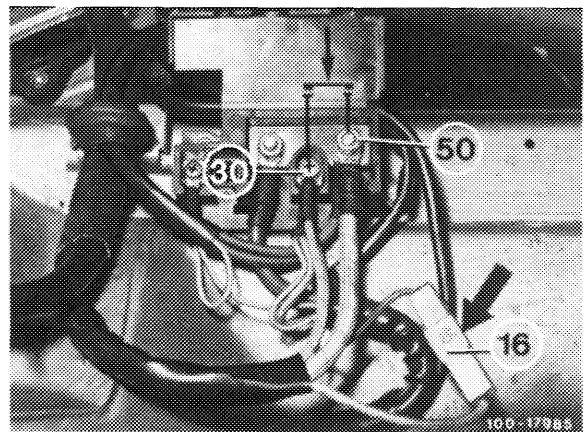

- 4 Remove rocker arm by means of the spring compressor.

Caution!

If rocker arms and camshafts are not replaced, reinstall them in the same position as before as failure to do so would require checking of the basic position of the hydraulic valve clearance compensating elements (05-213).

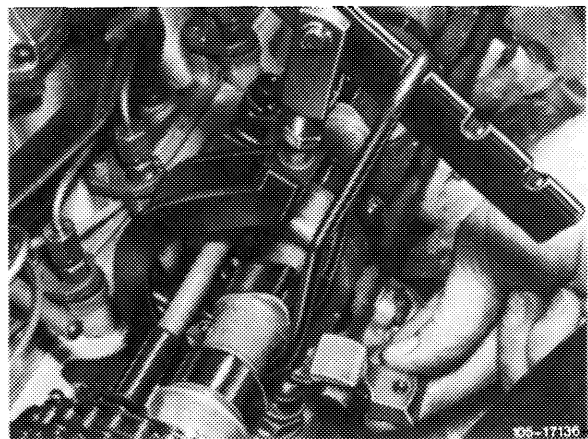

- 5 Set piston of No. 1 cylinder to ignition TDC, so that the Woodruff key in the camshaft (arrow) points up.

Note: Do not rotate engine on fastening bolt of camshaft sprockets.

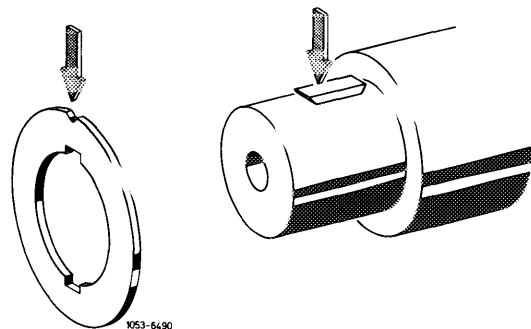

6 Prise off oil pipe with connections (arrows) and remove.

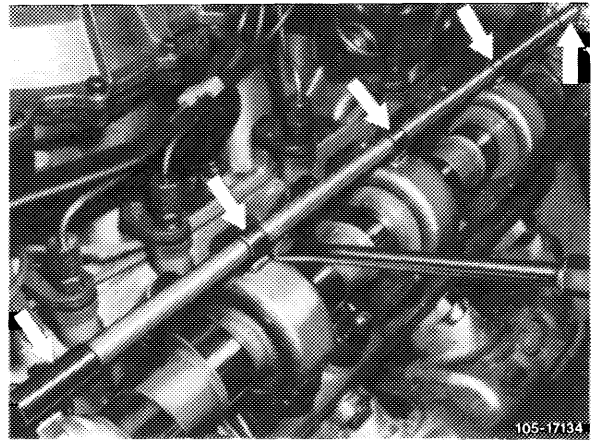

7 Mark timing chain and camshaft sprocket together with locking compound (arrows).

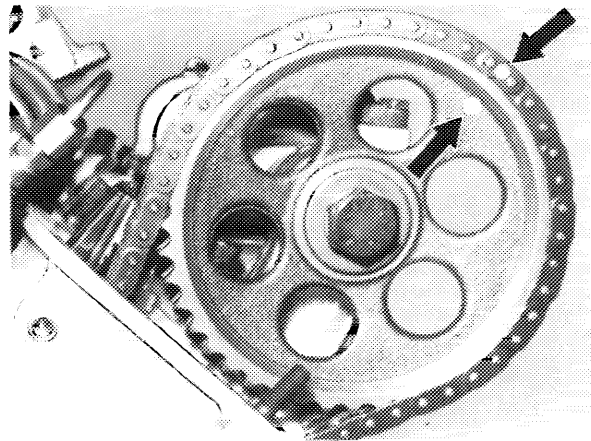

8 Loosen bolt on camshaft sprocket while holding it with the retaining wrench.

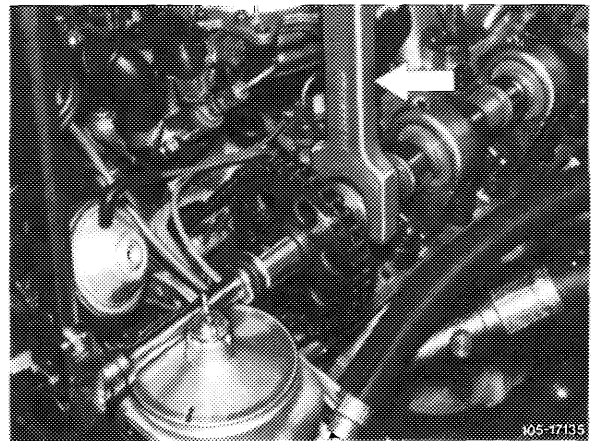

9 Unscrew camshaft bearing screws and remove.

Note: The rear cylinder head bolts M 10 x 165 mm (arrow) at left and right can be removed only after the camshaft bearing has been lifted.

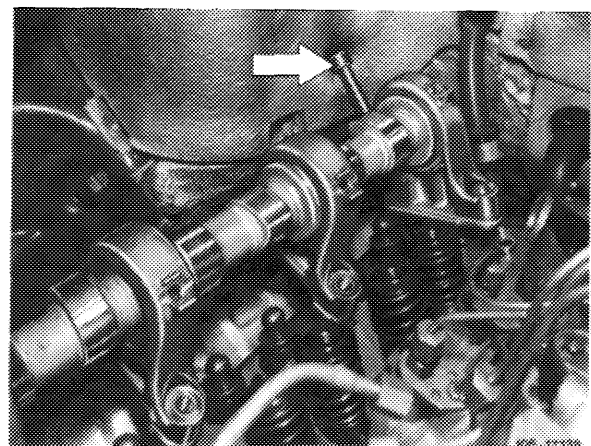

10 Lift camshaft including camshaft bearings and pull camshaft out of rear camshaft bearing.

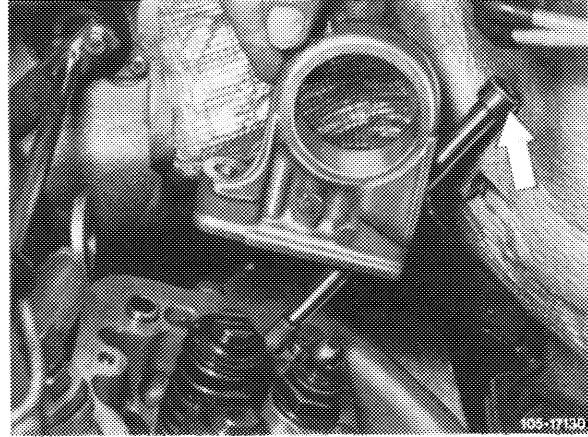

Installation

11 Lubricate camshaft bearings and slide camshaft into camshaft bearings.

Caution!

Introduce cylinder head bolts M 10 x 165 mm (arrow) at the rear camshaft bearing left and right before mounting the camshaft bearing.

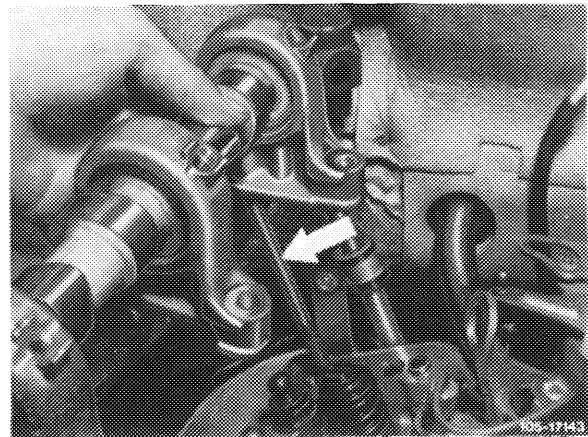

12 Lubricate cylinder head bolt threads and head contact area.

13 Mount camshafts with camshaft bearings.

14 Tighten cylinder head bolts M 10 x 165 for camshaft bearings from inside out first to 30 Nm initial torque and then to 60 Nm final torque.

15 Tighten fastening bolts M 8 to 50 Nm.

Caution!

The camshaft should turn easily by hand.

16 When mounting the oil pipes, move connections into assembly position and check the three inside connections for unobstructed passage of oil bores prior to tapping them onto the camshaft bearings. **Replace oil pipe if oil bores are covered up.**

Caution!

Replace connections each time following removal from camshaft bearings since otherwise the oil pressure in the oil pipe is not assured.

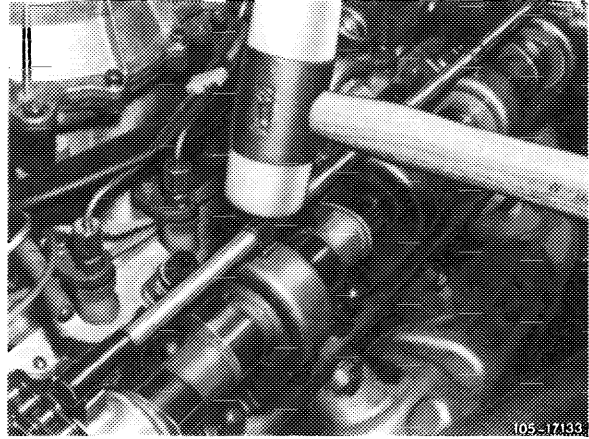

17 Mount compensating washer in such a manner that the groove below the notch engages with the Woodruff key of the camshaft (see arrows).

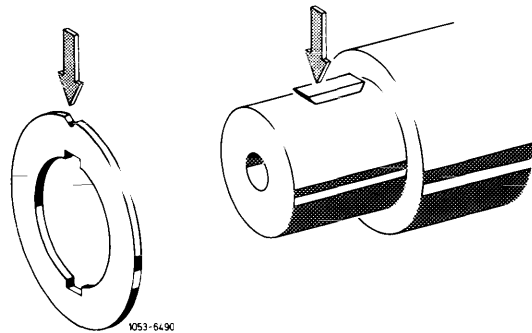

18 Mount camshaft sprocket while paying attention to the color coding (arrows).

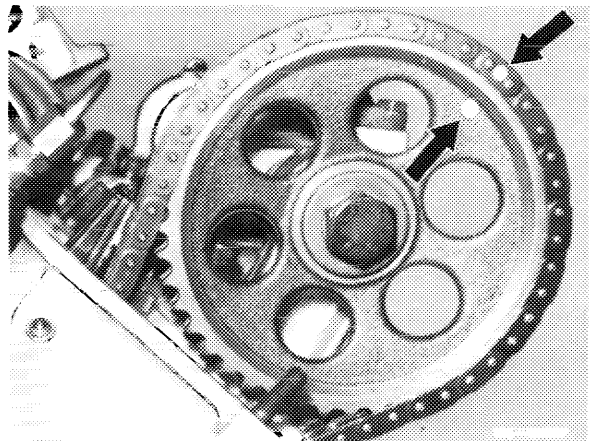

Caution!

The wide collar on the camshaft sprocket (arrow) should face to the camshaft.

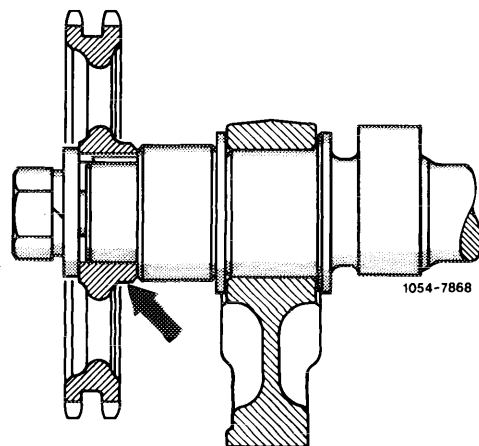

19 Mount bolt with washer and spring washer (arrow).

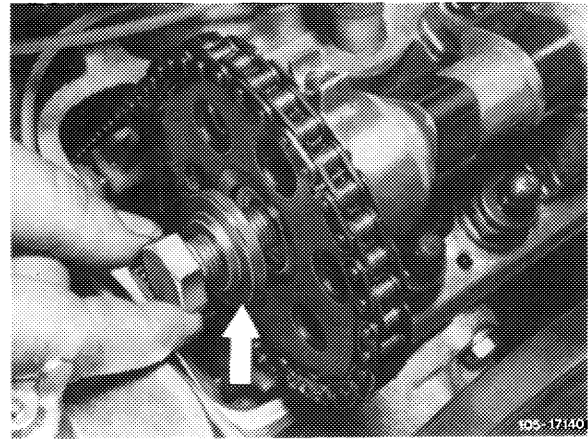

20 Tighten bolt to 100 Nm while holding the camshafts in place with the retaining wrench.

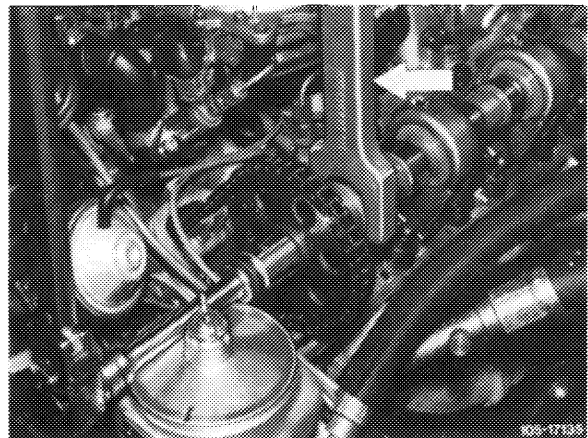

21 Install rocker arm in the same position as before.

Caution!

If the rocker arms or the camshaft have been replaced, check basic position of hydraulic valve clearance compensating elements (05-213).

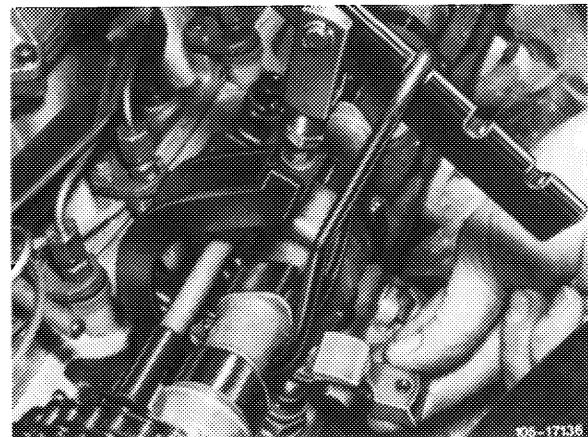

22 Complete the engine.

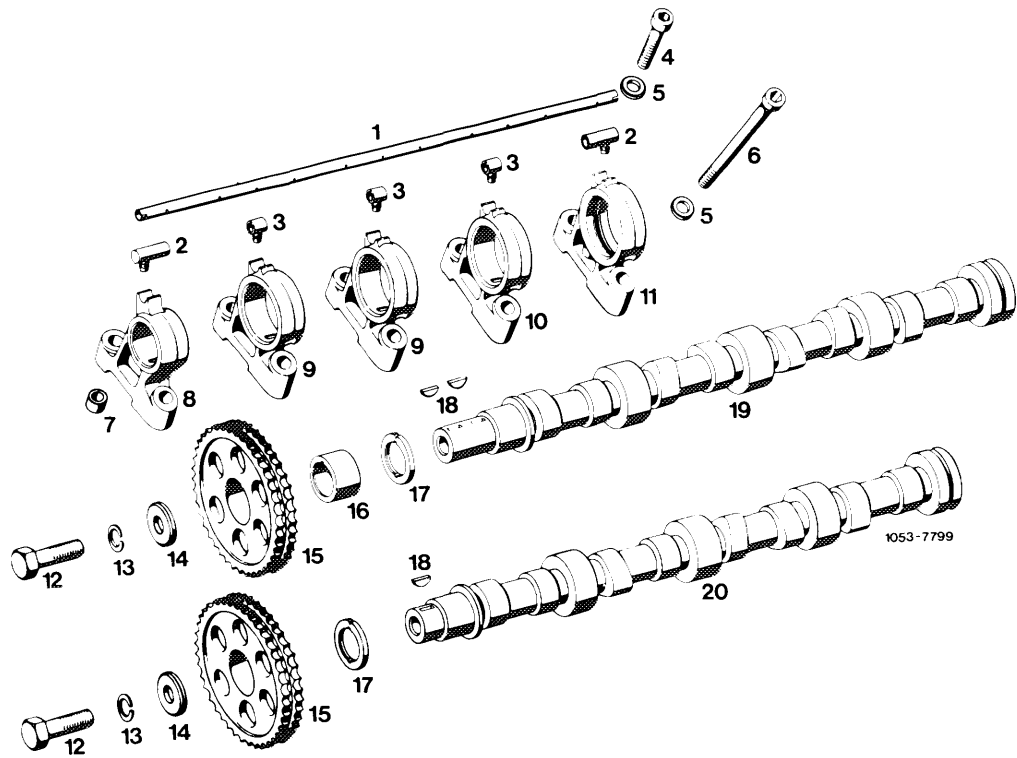

- | | | |
|---------------------------------|-----------------------------------|------------------------|
| 1 Oil pipe | 8 Camshaft bearing sprocket end | 14 Washer |
| 2 End connection | 9 Camshaft bearing 2 and 3 | 15 Camshaft sprocket |
| 3 Center connection | 10 Camshaft bearing 5 | 16 Spacer ring right |
| 4 Cylinder head bolt M 10 x 50 | 11 Camshaft bearing flywheel side | 17 Compensating washer |
| 5 Washer | 12 Bolt M 14 x 1.5 x 40 | 18 Woodruff key |
| 6 Cylinder head bolt M 10 x 165 | 13 Spring washer | 19 Camshaft right |
| 7 Dowel sleeve | | 20 Camshaft left |